

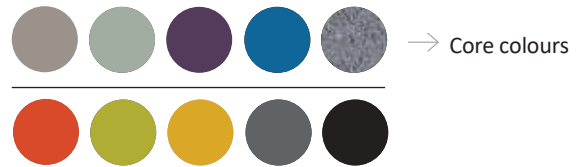

KEY FEATURES

- Heavily weighted to 85kg to deter mishandling (other weight options available)
- Ergonomically designed armrests to assist standing and sitting
- Anti-microbial, wipe-clean material protects throughout the product
- Wrap around arms help those with reduced mobility
- Water resistant, UV stabilised material makes items suitable for outdoor use
- Static load tested to a weight of 450kg



MATERIAL/FABRICATION

Rotationally moulded, durable polyethylene, one-piece construction provides excellent strength and stability. Flamed, textured finish further strengthens the fire-retardant, water-resistant, UV-stabilized shell. Small holes drilled in the seat make it suitable for outdoor use. Anti-microbial material gives high chemical resistance (e.g. ammonia, sodium hydroxide) throughout the product. Item is fully recyclable as polyethylene can be melted down to create a whole new product

TEST STANDARDS

- Tested to ANSI/BIFMA X5:5:2012 standards
- Fire retardant to CAL 133 and UL 94 HB
- Strength and stability tested for severe contract use (BS EN 16139:2013 Level 2). Exceeded the 200,000 cycles pass mark by a further 300,000 cycles
- UV resistance tested to UV 21+ stating it can withstand 21,000 sunlight hours
- Static load tested to a weight of 450kg

OPTIONS

- Floor fixing solution
- Upholstered seat 1RYU-02S (makes product not suitable for outdoor use)
- Lightweight model (18kg)

COLOUR/FINISH

[Core colours] Moonwalk Grey, Cool Green, Icon Purple, Epic Blue, Granite. [Other available colours] Blaze Orange, Lime, Vegas Yellow, Thunder Grey, Black

DELIVERY

ASSEMBLY

Arrives assembled and ready to use

INSTALLATION/FITTING

Additional weighting can be carried out prior to delivery. Please advise if floor fixing is required when ordering as fixed items are made differently. All products must be fitted carefully following Pineapple's product instructions (where available). If not, any guarantee is at risk of becoming null and void

MAINTENANCE

Our multi-purpose Ryno cleaning wipes are available to help keep your Ryno products looking their best. Avoid using abrasive materials or cleaning agents, solvents, steam cleaning or jet washing. Use bleach and chlorine disinfectant with caution and avoid placing in close proximity to sources of heat. Re

WARRANTY

Lifetime guarantee against all manufacturing faults

DISCLAIMER

Extreme temperature changes (e.g. a cold night followed by a warm sunny day) may cause air inside the product to expand, causing short-term changes to its shape

Due to the nature of the rotational moulding process, flat surfaces on Ryno[®] products may feature slight undulations which do not detract from the product's strength or durability.



UK Registered Design No. 6059839

KEY FEATURES

- Heavily weighted to 62kg to deter mishandling (other weight options available)
- Carefully considered curved design minimises ligature risks
- Sloping arms designed to minimise ligature risks
- Anti-microbial, wipe-clean material protects throughout the product
- Water resistant, UV stabilised material makes items suitable for outdoor use
- Static load tested to a weight of 450kg

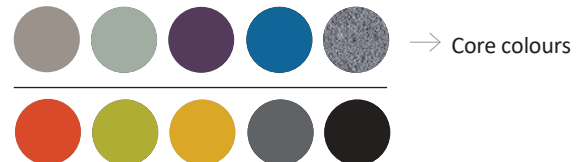

MATERIAL/FABRICATION

Rotationally moulded, durable polyethylene, one-piece construction provides excellent strength and stability. Flamed, textured finish further strengthens the fire-retardant, water-resistant, UV-stabilized shell. Small holes drilled in the seat make it suitable for outdoor use. Anti-microbial material gives high chemical resistance (e.g. ammonia, sodium hydroxide) throughout the product. Item is fully recyclable as polyethylene can be melted down to create a whole new product

TEST STANDARDS

- Tested to ANSI/BIFMA X5:5:2012 standards
- Fire retardant to CAL 133 and UL 94 HB
- Strength and stability tested for severe contract use (BS EN 16139:2013 Level 2). Exceeded the 200,000 cycles pass mark by a further 300,000 cycles
- UV resistance tested to UV 21+ stating it can withstand 21,000 sunlight hours
- Static load tested to a weight of 450kg

OPTIONS

- Floor fixing solution
- Linking brackets to connect chairs
- Lightweight model (18kg)

COLOUR/FINISH

[Core colours] Moonwalk Grey, Cool Green, Icon Purple, Epic Blue, Granite. [Other available colours] Blaze Orange, Lime, Vegas Yellow, Thunder Grey, Black

DELIVERY

ASSEMBLY

Arrives assembled and ready to use

INSTALLATION/FITTING

Additional weighting can be carried out prior to delivery. Please advise if floor fixing is required when ordering as fixed items are made differently. All products must be fitted carefully following Pineapple's product instructions (where available). If not, any guarantee is at risk of becoming null and void

MAINTENANCE

Our multi-purpose Ryno cleaning wipes are available to help keep your Ryno products looking their best. Avoid using abrasive materials or cleaning agents, solvents, steam cleaning or jet washing. Use bleach and chlorine disinfectant with caution and avoid placing in close proximity to sources of heat. Re

WARRANTY

Lifetime guarantee against all manufacturing faults

DISCLAIMER

Extreme temperature changes (e.g. a cold night followed by a warm sunny day) may cause air inside the product to expand, causing short-term changes to its shape

Due to the nature of the rotational moulding process, flat surfaces on Ryno[®] products may feature slight undulations which do not detract from the product's strength or durability.



KEY FEATURES

- Heavily weighted to 80kg to deter mishandling (other weight options available)
- Ergonomically designed to give excellent comfort
- Anti-microbial, wipe-clean material protects throughout the product
- Water resistant, UV stabilised material makes items suitable for outdoor use
- Chair static weight tested for bariatric use (withstands 317kg)
- Static weight tested to 450kg

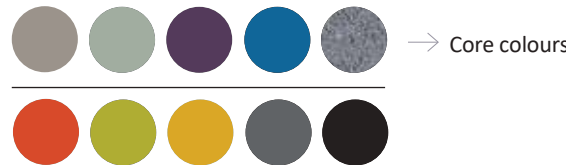

MATERIAL/FABRICATION

Rotationally moulded, durable polyethylene, one-piece construction provides excellent strength and stability. Flamed, textured finish further strengthens the fire-retardant, water-resistant, UV-stabilized shell. Small holes drilled in the seat make it suitable for outdoor use. Anti-microbial material gives high chemical resistance (e.g. ammonia, sodium hydroxide) throughout the product. Item is fully recyclable as polyethylene can be melted down to create a whole new product

TEST STANDARDS

- Tested to ANSI/BIFMA X5:5:2012 standards
- Fire retardant to CAL 133 and UL 94 HB
- Strength and stability tested for severe contract use (BS EN 16139:2013 Level 2). Exceeded the 200,000 cycles pass mark by a further 300,000 cycles
- UV resistance tested to UV 21+ stating it can withstand 21,000 sunlight hours
- Static load tested to a weight of 450kg

OPTIONS

- Upholstered seat and back pads (unsuitable for outdoors)
- Floor fixing solutions
- Linking brackets to connect chairs
- Lightweight model (13.5kg)

COLOUR/FINISH

[Core colours] Moonwalk Grey, Cool Green, Icon Purple, Epic Blue, Granite. [Other available colours] Blaze Orange, Lime, Vegas Yellow, Thunder Grey, Black

DELIVERY

ASSEMBLY

Arrives assembled and ready to use

INSTALLATION/FITTING

Additional weighting can be carried out prior to delivery. Please advise if floor fixing is required when ordering as fixed items are made differently. All products must be fitted carefully following Pineapple's product instructions (where available). If not, any guarantee is at risk of becoming null and void

MAINTENANCE

Our multi-purpose Ryno cleaning wipes are available to help keep your Ryno products looking their best. Avoid using abrasive materials or cleaning agents, solvents, steam cleaning or jet washing. Use bleach and chlorine disinfectant with caution and avoid placing in close proximity to sources of heat. Re

WARRANTY

Lifetime guarantee against all manufacturing faults

DISCLAIMER

Extreme temperature changes (e.g. a cold night followed by a warm sunny day) may cause air inside the product to expand, causing short-term changes to its shape

Due to the nature of the rotational moulding process, flat surfaces on Ryno[®] products may feature slight undulations which do not detract from the product's strength or durability.



KEY FEATURES

- Heavily weighted to 56kg as standard to deter misuse (other weight options available)
- Ergonomically designed to give excellent comfort
- Anti-microbial, wipe-clean material protects throughout the product
- Water resistant, UV stabilised material makes items suitable for outdoor use
- Static weight tested to 500kg

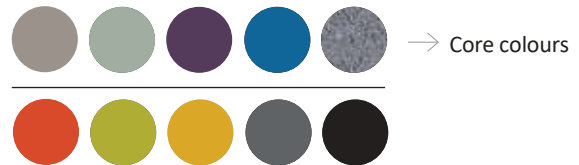

MATERIAL/FABRICATION

Rotationally moulded, durable polyethylene, one-piece construction provides excellent strength and stability. Flamed, textured finish further strengthens the fire-retardant, water-resistant, UV-stabilized shell. Small holes drilled in the seat make it suitable for outdoor use. Anti-microbial material gives high chemical resistance (e.g. ammonia, sodium hydroxide) throughout the product. Item is fully recyclable as polyethylene can be melted down to create a whole new product

TEST STANDARDS

- Tested to ANSI/BIFMA X5:5:2012 standards
- Fire retardant to CAL 133 and UL 94 HB
- Strength and stability tested for severe contract use (BS EN 16139:2013 Level 2). Exceeded the 200,000 cycles pass mark by a further 300,000 cycles
- UV resistance tested to UV 21+ stating it can withstand 21,000 sunlight hours
- Static load tested to a weight of 500kg

OPTIONS

- Upholstered seat and back pads (unsuitable for outdoors)
- Floor fixing solutions
- Linking brackets to connect chairs
- Lightweight model (12kg)

COLOUR/FINISH

[Core colours] Moonwalk Grey, Cool Green, Icon Purple, Epic Blue, Granite. [Other available colours] Blaze Orange, Lime, Vegas Yellow, Thunder Grey, Black

DELIVERY

ASSEMBLY

Arrives assembled and ready to use

INSTALLATION/FITTING

Additional weighting can be carried out prior to delivery. Please advise if floor fixing is required when ordering as fixed items are made differently. All products must be fitted carefully following Pineapple's product instructions (where available). If not, any guarantee is at risk of becoming null and void

MAINTENANCE

Our multi-purpose Ryno cleaning wipes are available to help keep your Ryno products looking their best. Avoid using abrasive materials or cleaning agents, solvents, steam cleaning or jet washing. Use bleach and chlorine disinfectant with caution and avoid placing in close proximity to sources of heat. Re

WARRANTY

Lifetime guarantee against all manufacturing faults

DISCLAIMER

Extreme temperature changes (e.g. a cold night followed by a warm sunny day) may cause air inside the product to expand, causing short-term changes to its shape

Due to the nature of the rotational moulding process, flat surfaces on Ryno[®] products may feature slight undulations which do not detract from the product's strength or durability.



KEY FEATURES

- Heavily weighted to 30kg as standard to deter misuse (other weight options available)
- Ergonomically designed to give excellent comfort
- Anti-microbial, wipe-clean material protects throughout the product
- Water resistant, UV stabilised material makes items suitable for outdoor use
- Designed for Sizemark 4 posture requirements (stature range 1330-1590mm)

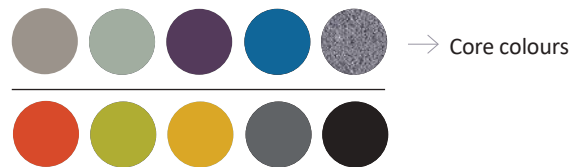

MATERIAL/FABRICATION

Rotationally moulded, durable polyethylene, one-piece construction provides excellent strength and stability. Flamed, textured finish further strengthens the fire-retardant, water-resistant, UV-stabilized shell. Small holes drilled in the seat make it suitable for outdoor use. Anti-microbial material gives high chemical resistance (e.g. ammonia, sodium hydroxide) throughout the product. Item is fully recyclable as polyethylene can be melted down to create a whole new product

TEST STANDARDS

- Strength and stability tested to BS EN 16139:2013 - Level 2 (severe contract use)
- Tested to ANSI/BIFMA X5:5:2012 standards
- Fire retardant to BS 5852:2006 ignition source 5, to CAL 133 and UL 94 HB
- UV resistance tested to UV 21+ stating it can withstand 21,000 sunlight hours

OPTIONS

- Upholstered seat and back pads (unsuitable for outdoors)
- Floor fixing solutions
- Linking brackets to connect chairs
- Lightweight model (12kg)

COLOUR/FINISH

[Core colours] Moonwalk Grey, Cool Green, Icon Purple, Epic Blue, Granite. [Other available colours] Blaze Orange, Lime, Vegas Yellow, Thunder Grey, Black

DELIVERY

ASSEMBLY

Arrives assembled and ready to use

INSTALLATION/FITTING

Additional weighting can be carried out prior to delivery. Please advise if floor fixing is required when ordering as fixed items are made differently. All products must be fitted carefully following Pineapple's product instructions (where available). If not, any guarantee is at risk of becoming null and void

MAINTENANCE

Our multi-purpose Ryno cleaning wipes are available to help keep your Ryno products looking their best. Avoid using abrasive materials or cleaning agents, solvents, steam cleaning or jet washing. Use bleach and chlorine disinfectant with caution and avoid placing in close proximity to sources of heat. Re:

WARRANTY

Lifetime guarantee against all manufacturing faults

DISCLAIMER

Extreme temperature changes (e.g. a cold night followed by a warm sunny day) may cause air inside the product to expand, causing short-term changes to its shape

Due to the nature of the rotational moulding process, flat surfaces on Ryno[®] products may feature slight undulations which do not detract from the product's strength or durability.

DOMUS CHAIR

1DU1

770 H | 730W | 700D (mm)

Seat Height: 450mm

Weight: 41kg



KEY FEATURES

- Standard reinforcement provides strength and durability
- Immensely strong 25mm veneered plywood construction
- Seat platform rebated into back for additional strength
- Heavyweight to deter mishandling



MATERIAL/FABRICATION

The Domus tub chairs are a classically styled chair that is stylish and comfortable. The wrap-around back and arm design make this range extremely robust and durable. The Domus chair is available as a one or two-seater. Cushioned seat made from fire retardant, CMHR (combustion modified high resilience) foam is safe for both users and staff

TEST STANDARDS

- Strength and stability tested to BS EN 15372:2008 - Level 2
- Fire retardant to BS 7176:2007 source 5

OPTIONS

- Available in Standard or Plus levels of reinforcement
- Removable seat cushion for easy cleaning
- Available with or without slots

FABRIC

Available in a wide choice of fabrics including Vinyl, Waterproof, Non Waterproof and Leather

COLOUR/FINISH

Shell available in Natural

ASSEMBLY

Arrives assembled and ready to use

DELIVERY

INSTALLATION/FITTING

No fitting required

MAINTENANCE

A regular light dusting with a soft cloth is all that is required to maintain the shell's appearance. Real wood veneers are soft and can be scratched relatively easily, so it is important to avoid using abrasive materials for cleaning and care should be taken when moving items with a rough surface so as not to damage the surface. Excessive amounts of water should be avoided as this too will damage the veneer. Check before using furniture polish that it is safe for use on real wood veneers. See upholstered furniture section of our care guidelines for fabric care instructions

WARRANTY

7 year guarantee (does not include fabrics)



KEY FEATURES

- Fully enclosed base to minimise concealment opportunities
- Immensely strong 25mm veneered plywood construction
- Seat platform rebated into back for additional strength
- Heavyweight to deter mishandling
- Seat static weight tested to 200kg



MATERIAL/FABRICATION

Immensely strong veneered 25mm plywood shell. Seat platform rebated into back for additional strength and stability. Base is fully enclosed to prevent concealment of contraband. Seat cushion fixed to the base to ensure that it is not taken off. Cushioned seat made from fire retardant, CMHR (combustion modified high resilience) foam is safe for both users and staff

TEST STANDARDS

- Strength and stability tested to BS EN 15372:2008 - Level 2
- Fire retardant to BS 7176:2007 source 5
- Seat static weight tested to 200kg

OPTIONS

- Available in Standard or Plus levels of reinforcement
- Removable seat cushion for easy cleaning
- Available with or without slots

FABRIC

Available in a wide choice of fabrics including Vinyl, Waterproof, Non Waterproof and Leather

COLOUR/FINISH

Shell available in Natural

ASSEMBLY

Arrives assembled and ready to use

DELIVERY

INSTALLATION/FITTING

No fitting required

MAINTENANCE

A regular light dusting with a soft cloth is all that is required to maintain the shell's appearance. Real wood veneers are soft and can be scratched relatively easily, so it is important to avoid using abrasive materials for cleaning and care should be taken when moving items with a rough surface so as not to damage the surface. Excessive amounts of water should be avoided as this too will damage the veneer. Check before using furniture polish that it is safe for use on real wood veneers. See upholstered furniture section of our care guidelines for fabric care instructions

WARRANTY

7 year guarantee (does not include fabrics)

DOMUS 2-SEATER

1DU2

770H | 1360W | 700D (mm)

Seat Height: 450mm

Weight: 77kg



KEY FEATURES

- Standard reinforcement provides strength and durability
- Immensely strong 25mm veneered plywood construction
- Seat platform rebated into back for additional strength
- Heavyweight to deter mishandling



MATERIAL/FABRICATION

The Domus 2-Seaters are a classically styled chair that is stylish and comfortable. The wrap-around back and arm design make this range extremely robust and durable. The Domus range is available as a one or two-seater. Cushioned seat made from fire retardant, CMHR (combustion modified high resilience) foam is safe for both users and staff

TEST STANDARDS

- Strength and stability tested to BS EN 15372:2008 - Level 2
- Fire retardant to BS 7176:2007 source 5

OPTIONS

- Available in Standard or Plus levels of reinforcement
- Removable seat cushion for easy cleaning
- Available with or without slots

FABRIC

Available in a wide choice of fabrics including Vinyl, Waterproof, Non Waterproof and Leather

COLOUR/FINISH

Shell available in Natural

ASSEMBLY

Arrives assembled and ready to use

DELIVERY

INSTALLATION/FITTING

No fitting required

MAINTENANCE

A regular light dusting with a soft cloth is all that is required to maintain the shell's appearance. Real wood veneers are soft and can be scratched relatively easily, so it is important to avoid using abrasive materials for cleaning and care should be taken when moving items with a rough surface so as not to damage the surface. Excessive amounts of water should be avoided as this too will damage the veneer. Check before using furniture polish that it is safe for use on real wood veneers. See upholstered furniture section of our care guidelines for fabric care instructions

WARRANTY

7 year guarantee (does not include fabrics)

DOMUS PLUS 2-SEATER

1DUP2

770H | 1360W | 700D (mm)

Seat Height: 450mm

Weight: 85kg



KEY FEATURES

- Fully enclosed base to minimise concealment opportunities
- Immensely strong 25mm veneered plywood construction
- Seat platform rebated into back for additional strength
- Heavyweight to deter mishandling
- Seat static weight tested to 200kg



MATERIAL/FABRICATION

Immensely strong veneered 25mm plywood shell. Seat platform rebated into back for additional strength and stability. Base is fully enclosed to prevent concealment of contraband. Seat cushion fixed to the base to ensure that it is not taken off. Cushioned seat made from fire retardant, CMHR (combustion modified high resilience) foam is safe for both users and staff

TEST STANDARDS

- Strength and stability tested to BS EN 15372:2008 - Level 2
- Fire retardant to BS 7176:2007 source 5
- Seat static weight tested to 200kg

OPTIONS

- Available in Standard or Plus levels of reinforcement
- Removable seat cushion for easy cleaning
- Available with or without slots

FABRIC

Available in a wide choice of fabrics including Vinyl, Waterproof, Non Waterproof and Leather

COLOUR/FINISH

Shell available in Natural

ASSEMBLY

Arrives assembled and ready to use

DELIVERY

INSTALLATION/FITTING

No fitting required

MAINTENANCE

A regular light dusting with a soft cloth is all that is required to maintain the shell's appearance. Real wood veneers are soft and can be scratched relatively easily, so it is important to avoid using abrasive materials for cleaning and care should be taken when moving items with a rough surface so as not to damage the surface. Excessive amounts of water should be avoided as this too will damage the veneer. Check before using furniture polish that it is safe for use on real wood veneers. See upholstered furniture section of our care guidelines for fabric care instructions

WARRANTY

7 year guarantee (does not include fabrics)

PURL HIGH BACK ARMCHAIR

1PUH1-100

1070H | 700W | 780D (mm)

Seat Height: 480mm

Weight: 28kg



KEY FEATURES

- Standard reinforcement provides strength and durability
- Wrap-around design of the seat back gives great comfort and support
- 480mm seat height designed to help reduced mobility
- Fixed seat cushion to deter misuse



MATERIAL/FABRICATION

Expanding our seating range with an update on our popular Eclipse range. Our Purl range offers standard reinforcement for strength and durability, also a fixed seat cushion to deter misuse. 480mm seat height has been designed to help those with reduced mobility. Fixed upholstered cushioned seat is made from fire retardant, CMHR (combustion modified high resilience) foam is safe for both users and staff. Chrome metal feet (height: 120mm) gives the range a modern and clean appearance.

TEST STANDARDS

- Strength and stability tested to BS EN 16139:2013 (Test level 2 - general use)
- Fabrics fire retardancy - BS 7176:2007 Source 5

OPTIONS

- Also available in a Purl Plus range
- Also available as Purl low back armchair (see below)
- Purl footstool is available (see below)

1PUL1-100
870H | 700W | 780D (mm)
Seat Height: 480mm
Weight: 25kg



1PUS-100
420H | 500W | 450D (mm)
Weight: 7.5kg



FINISH

Available with chrome or natural wood feet

FABRICS

Available in a wide choice of fabrics including Vinyl, Waterproof, Non Waterproof and Leather

ASSEMBLY

Arrives assembled and ready to use

DELIVERY

INSTALLATION/FITTING

No fitting required

MAINTENANCE

See our care guidelines for more information

WARRANTY

7 year guarantee (does not include fabrics)

PURL HIGH BACK ARMCHAIR

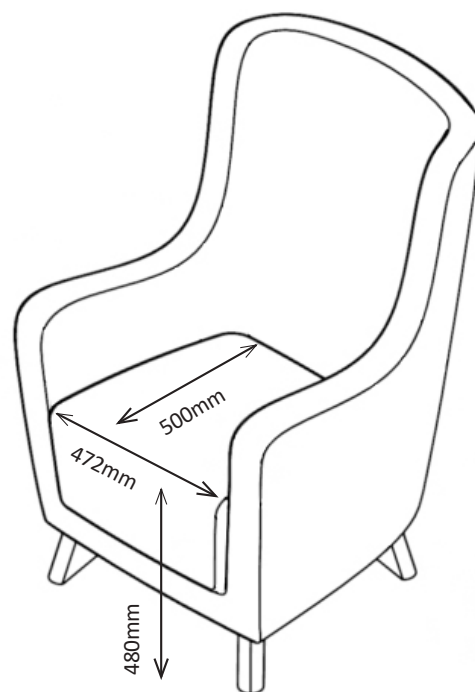
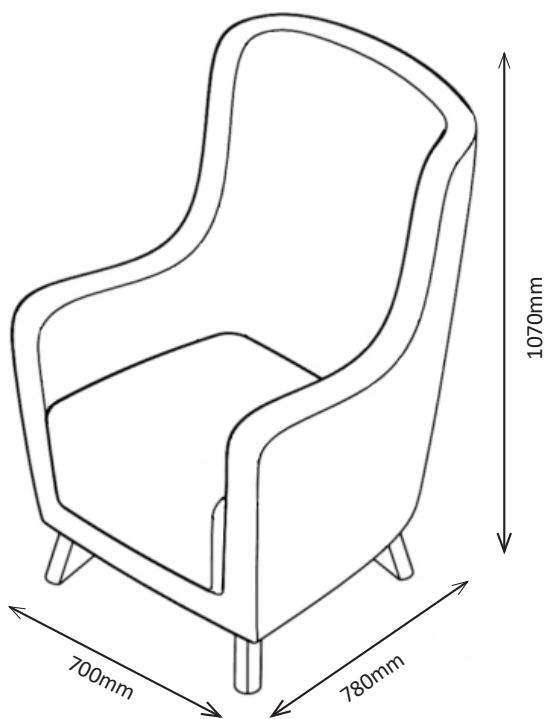

072 836 6193 / 021 201 7199

enquiries@apex-ergo.co.za

www.apex-ergo.co.za



KEY FEATURES

- Standard reinforcement provides strength and durability
- Wrap-around design of the seat back gives great comfort and support
- 480mm seat height designed to help reduced mobility
- Fixed seat cushion to deter misuse



MATERIAL/FABRICATION

Expanding our seating range with an update on our popular Eclipse range. Our Purl range offers standard reinforcement for strength and durability, also a fixed seat cushion to deter misuse. 480mm seat height has been designed to help those with reduced mobility. Fixed upholstered cushioned seat is made from fire retardant, CMHR (combustion modified high resilience) foam is safe for both users and staff. Chrome metal feet (height: 120mm) gives the range a modern and clean appearance.

TEST STANDARDS

- Strength and stability tested to BS EN 16139:2013 (Test level 2 - general use)
- Fabrics fire retardancy - BS 7176:2007 Source 5

OPTIONS

- Also available in a Purl Plus range
- Also available as Purl high back armchair (see below)
- Purl footstool is available (see below)

1PUH1-100
1070H | 700W | 780D (mm)
Seat Height: 480mm
Weight: 28kg



1PUS-100
420H | 500W | 450D (mm)
Weight: 7.5kg



FINISH

Available with chrome or natural wood feet

FABRICS

Available in a wide choice of fabrics including Vinyl, Waterproof, Non Waterproof and Leather

ASSEMBLY

Arrives assembled and ready to use

DELIVERY

INSTALLATION/FITTING

No fitting required

MAINTENANCE

See our care guidelines for more information

WARRANTY

7 year guarantee (does not include fabrics)

PURL LOW BACK ARMCHAIR

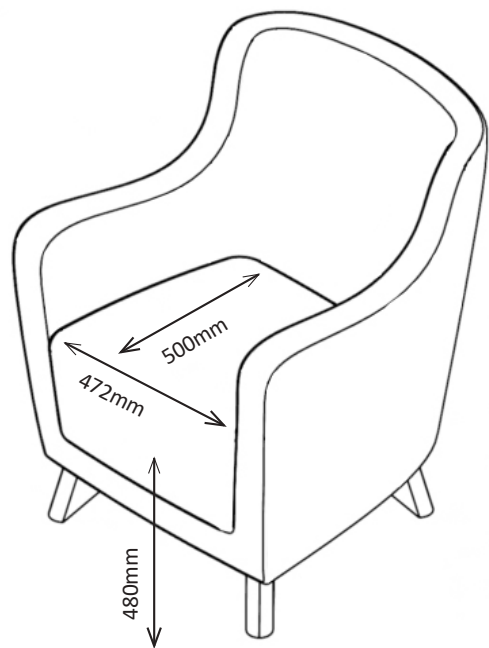
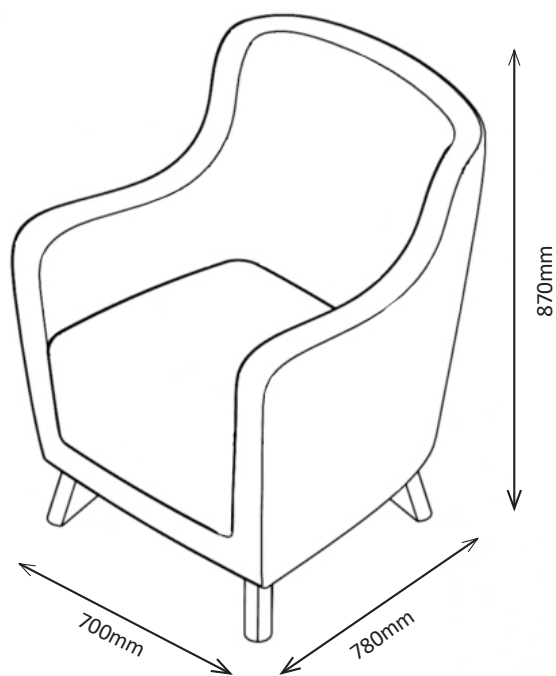

072 836 6193 / 021 201 7199

enquiries@apex-ergo.co.za

www.apex-ergo.co.za

PURL PLUS HIGH BACK ARMCHAIR

1PUHP1-400

1070H | 700W | 780D (mm)

Seat Height: 480mm

Weight: 41kg



KEY FEATURES

- Additional weight for added safety
- Wrap-around design of the seat back provides comfort and support
- 480mm seat height designed to help those with reduced mobility
- Fixed seat cushion to deter misuse
- Fully enclosed base with inaccessible fixings to prevent tampering
- Seat static weight tested to 200kg

UK Registered Design No. 6131291 / 6131292 / 6131293 / 6131294



MATERIAL/FABRICATION

Our Purl Plus range has additional weight and reinforcement and has a fully enclosed base to deter tampering. Other features include a fixed seat cushion to deter misuse. 480mm seat height has been designed to help those with reduced mobility. Fixed upholstered cushioned seat is made from fire retardant, CMHR (combustion modified high resilience) foam is safe for both users and staff. Chrome metal feet (height: 120mm) gives the range a modern and clean appearance.

TEST STANDARDS

- Strength and stability tested to BS EN 16139:2013 (Test level 2 - general use)
- Fabrics fire retardancy - BS 7176:2007 Source 5
- Seat static weight tested to 200kg

OPTIONS

- Also available as a standard Purl range
- Also available as a Purl Plus 2-Seater option
- Available as Purl Plus low back armchair (see below)

1PULP1-400
870H | 700W | 780D (mm)
Seat Height: 480mm
Weight: 38kg



FINISH

Available with chrome or natural wood feet

FABRICS

Available in a wide choice of fabrics including Vinyl, Waterproof, Non Waterproof and Leather

ASSEMBLY

Arrives assembled and ready to use

DELIVERY

INSTALLATION/FITTING

No fitting required

MAINTENANCE

See our care guidelines for more information

WARRANTY

7 year guarantee (does not include fabrics)

PURL PLUS HIGH BACK ARMCHAIR

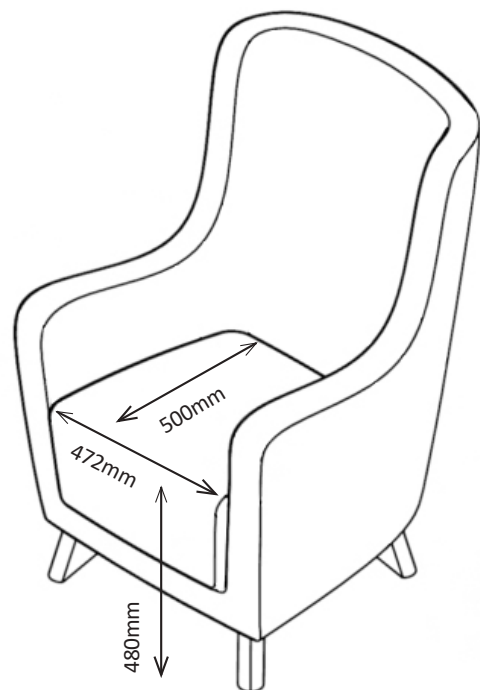
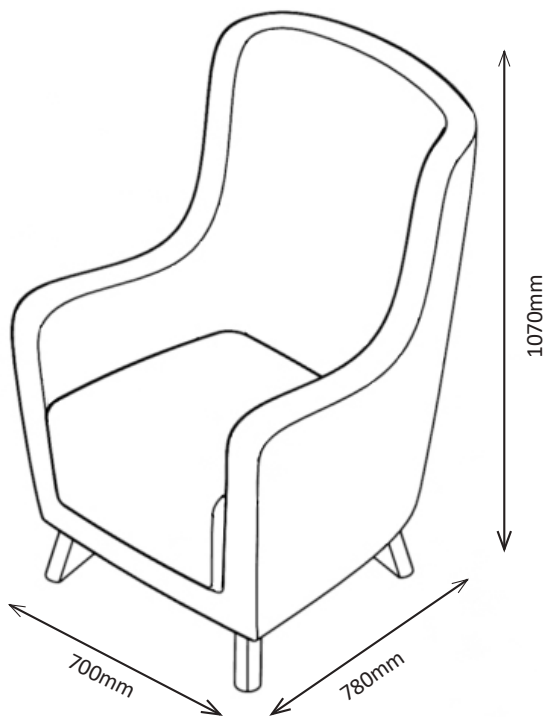

072 836 6193 / 021 201 7199

enquiries@apex-ergo.co.za

www.apex-ergo.co.za



PURL PLUS LOW BACK ARMCHAIR

1PULP1-400

870H | 700W | 780D (mm)

Seat Height: 480mm

Weight: 38kg



UK Registered Design No. 6131291 / 6131292 / 6131293 / 6131294



KEY FEATURES

- Additional weight for added safety
- Wrap-around design of the seat back provides comfort and support
- 480mm seat height designed to help those with reduced mobility
- Fixed seat cushion to deter misuse
- Fully enclosed base with inaccessible fixings to prevent tampering
- Seat static weight tested to 200kg

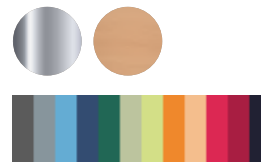

MATERIAL/FABRICATION

Our Purl Plus range has additional weight and reinforcement and has a fully enclosed base to deter tampering. Other features include a fixed seat cushion to deter misuse. 480mm seat height has been designed to help those with reduced mobility. Fixed upholstered cushioned seat is made from fire retardant, CMHR (combustion modified high resilience) foam is safe for both users and staff. Chrome metal feet (height: 120mm) gives the range a modern and clean appearance.

TEST STANDARDS

- Strength and stability tested to BS EN 16139:2013 (Test level 2 - general use)
- Fabrics fire retardancy - BS 7176:2007 Source 5
- Seat static weight tested to 200kg

OPTIONS

- Also available as a standard Purl range
- Also available as a Purl Plus 2-Seater option
- Available as Purl Plus high back armchair (see below)

1PUHP1-400
1070H | 700W | 780D (mm)
Seat Height: 480mm
Weight: 41kg



FINISH

Available with chrome or natural wood feet

FABRICS

Available in a wide choice of fabrics including Vinyl, Waterproof, Non Waterproof and Leather

ASSEMBLY

Arrives assembled and ready to use

DELIVERY

INSTALLATION/FITTING

No fitting required

MAINTENANCE

See our care guidelines for more information <http://www.apex-ergo.co.za>

WARRANTY

7 year guarantee (does not include fabrics)

PURL PLUS LOW BACK ARMCHAIR

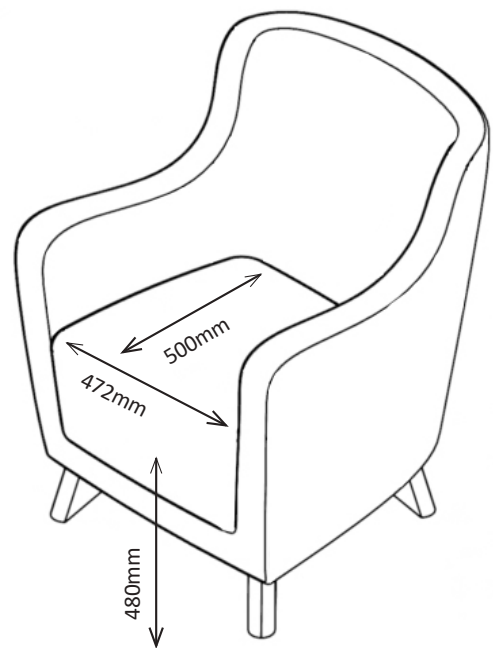
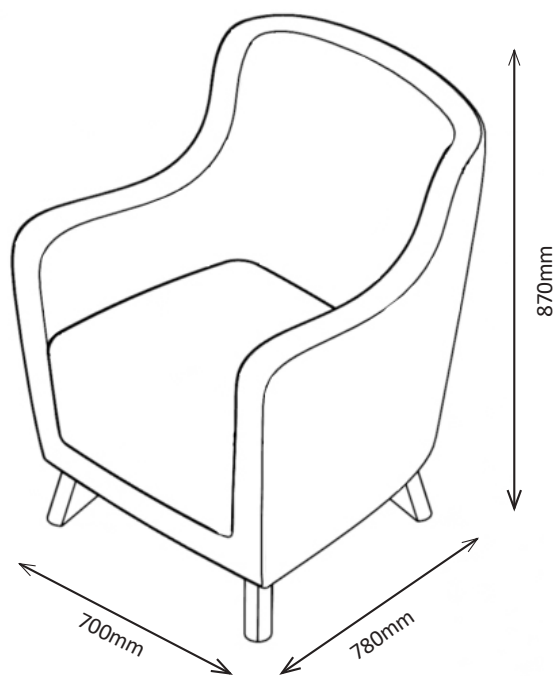

PURL HIGH BACK 2-SEATER

1PUH2-100

1070H | 1190W | 780D (mm)

Seat Height: 480mm

Weight: 38.5kg



KEY FEATURES

- Standard reinforcement provides strength and durability
- Wrap-around design of the seat back gives great comfort and support
- 480mm seat height designed to help reduced mobility
- Fixed seat cushion to deter misuse



MATERIAL/FABRICATION

Expanding our seating range with an update on our popular Eclipse range. Our Purl range offers standard reinforcement for strength and durability, also a fixed seat cushion to deter misuse. 480mm seat height has been designed to help those with reduced mobility. Fixed upholstered cushioned seat is made from fire retardant, CMHR (combustion modified high resilience) foam is safe for both users and staff. Chrome metal feet (height: 120mm) gives the range a modern and clean appearance.

TEST STANDARDS

- Strength and stability tested to BS EN 16139:2013 (Test level 2 - general use)
- Fabrics fire retardancy - BS 7176:2007 Source 5

OPTIONS

- Also available in a Purl Plus range
- Also available as Purl low back 2-Seater (see below)
- Purl footstool is available (see below)

1PUL2-100
870H | 1190W | 780D (mm)
Seat Height: 480mm
Weight: 34.5kg



1PUS-100
420H | 500W | 450D (mm)
Weight: 7.5kg



FINISH

Available with chrome or natural wood feet

FABRICS

Available in a wide choice of fabrics including Vinyl, Waterproof, Non Waterproof and Leather

ASSEMBLY

Arrives assembled and ready to use

DELIVERY

INSTALLATION/FITTING

No fitting required

MAINTENANCE

See our care guidelines for more information

WARRANTY

7 year guarantee (does not include fabrics)

PURL HIGH BACK 2-SEATER

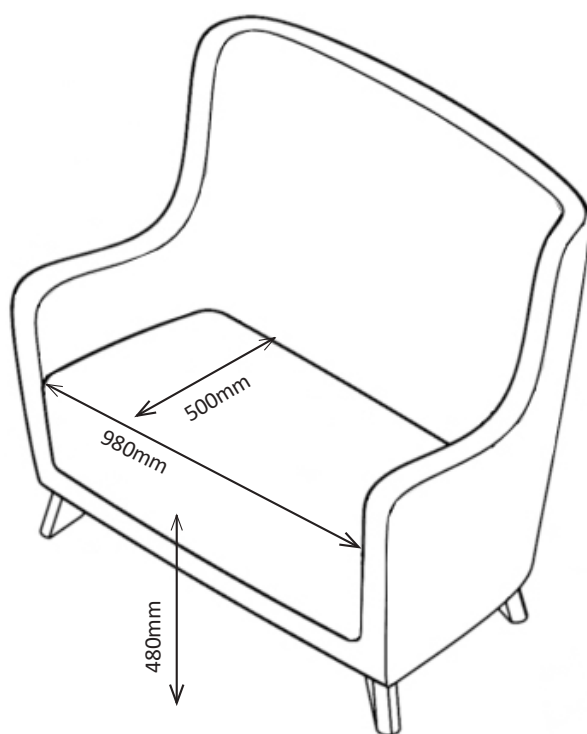
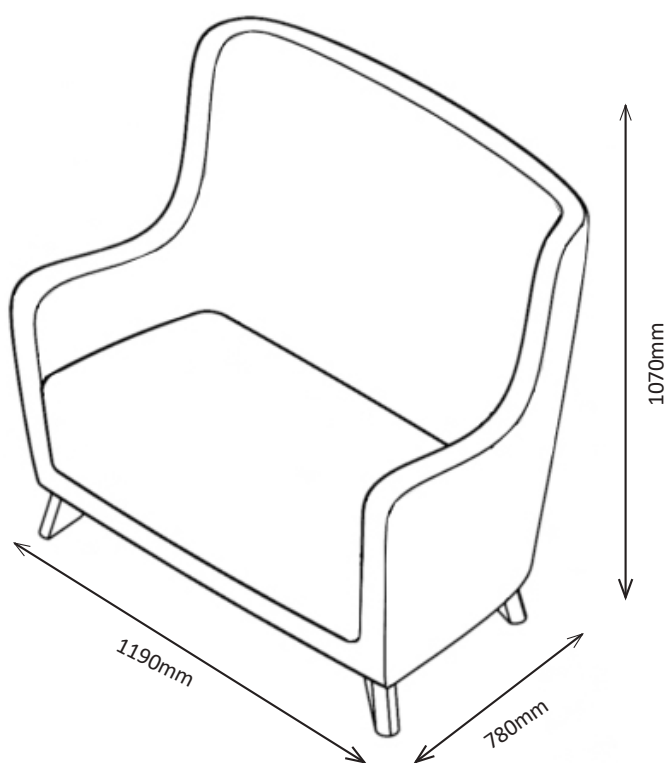

PURL LOW BACK 2-SEATER

1PUL2-100

870H | 1190W | 780D (mm)

Seat Height: 480mm

Weight: 34.5kg



KEY FEATURES

- Standard reinforcement provides strength and durability
- Wrap-around design of the seat back gives great comfort and support
- 480mm seat height designed to help reduced mobility
- Fixed seat cushion to deter misuse



MATERIAL/FABRICATION

Expanding our seating range with an update on our popular Eclipse range. Our Purl range offers standard reinforcement for strength and durability, also a fixed seat cushion to deter misuse. 480mm seat height has been designed to help those with reduced mobility. Fixed upholstered cushioned seat is made from fire retardant, CMHR (combustion modified high resilience) foam is safe for both users and staff. Chrome metal feet (height: 120mm) gives the range a modern and clean appearance.

TEST STANDARDS

- Strength and stability tested to BS EN 16139:2013 (Test level 2 - general use)
- Fabrics fire retardancy - BS 7176:2007 Source 5

OPTIONS

- Also available in a Purl Plus range
- Also available as Purl high back armchair (see below)
- Purl footstool is available (see below)

1PUH2-100
1070H | 1190W | 780D (mm)
Seat Height: 480mm
Weight: 38.5kg



1PUS-100
420H | 500W | 450D (mm)
Weight: 7.5kg



FINISH

Available with chrome or natural wood feet

FABRICS

Available in a wide choice of fabrics including Vinyl, Waterproof, Non Waterproof and Leather

ASSEMBLY

Arrives assembled and ready to use

DELIVERY

INSTALLATION/FITTING

No fitting required

MAINTENANCE

See our care guidelines for more information

WARRANTY

7 year guarantee (does not include fabrics)

PURL LOW BACK 2-SEATER

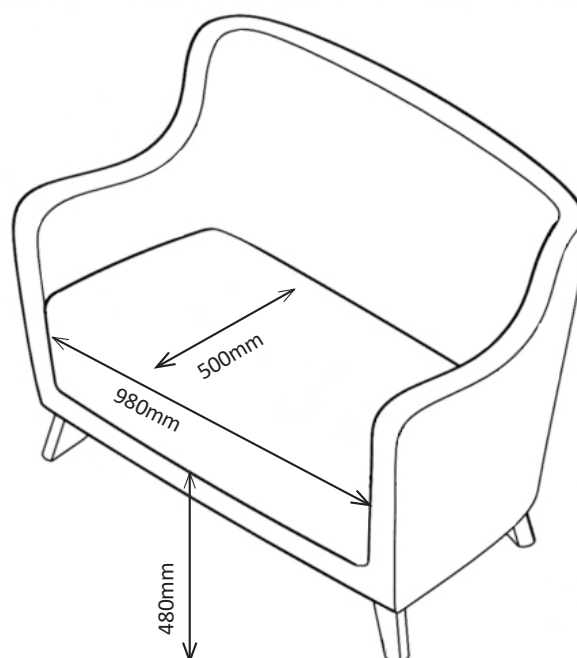
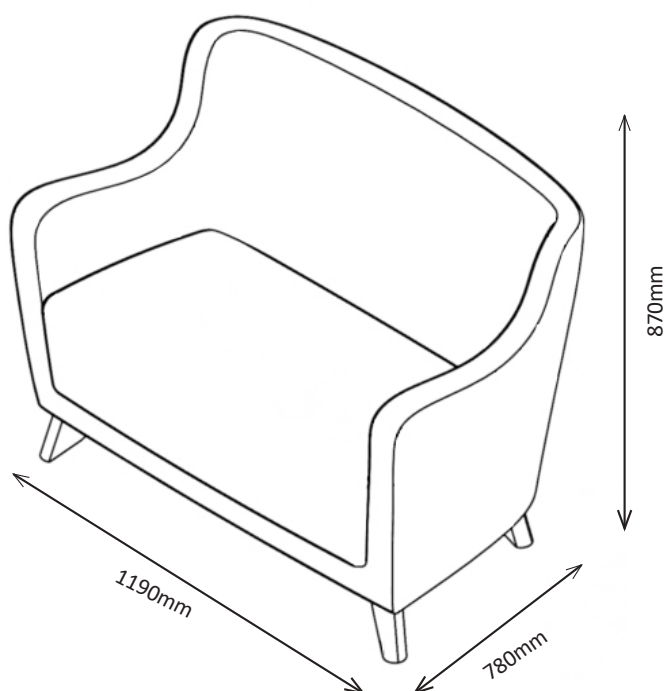

PURL PLUS HIGH BACK 2-SEATER

1PUHP2-400

1070H | 1190W | 780D (mm)

Seat Height: 480mm

Weight: 56.5kg



KEY FEATURES

- Additional weight for added safety
- Wrap-around design of the seat back provides comfort and support
- 480mm seat height designed to help those with reduced mobility
- Fixed seat cushion to deter misuse
- Fully enclosed base with inaccessible fixings to prevent tampering
- Seat static weight tested to 200kg



UK Registered Design No. 6131291 / 6131292 / 6131293 / 6131294



MATERIAL/FABRICATION

Our Purl Plus range has additional weight and reinforcement and has a fully enclosed base to deter tampering. Other features include a fixed seat cushion to deter misuse. 480mm seat height has been designed to help those with reduced mobility. Fixed upholstered cushioned seat is made from fire retardant, CMHR (combustion modified high resilience) foam is safe for both users and staff. Chrome metal feet (height: 120mm) gives the range a modern and clean appearance.

TEST STANDARDS

- Strength and stability tested to BS EN 16139:2013 (Test level 2 - general use)
- Fabrics fire retardancy - BS 7176:2007 Source 5
- Seat static weight tested to 200kg

OPTIONS

- Also available as a standard Purl range
- Also available as a Purl Plus armchair option
- Available as Purl Plus low back 2-Seater (see below)

1PULP2-400
870H | 1190W | 780D (mm)
Seat Height: 480mm
Weight: 52.5kg



FINISH

Available with chrome or natural wood feet

FABRICS

Available in a wide choice of fabrics including Vinyl, Waterproof, Non Waterproof and Leather

ASSEMBLY

Arrives assembled and ready to use

DELIVERY

INSTALLATION/FITTING

No fitting required

MAINTENANCE

See our care guidelines for more information

WARRANTY

7 year guarantee (does not include fabrics)

PURL PLUS HIGH BACK 2-SEATER

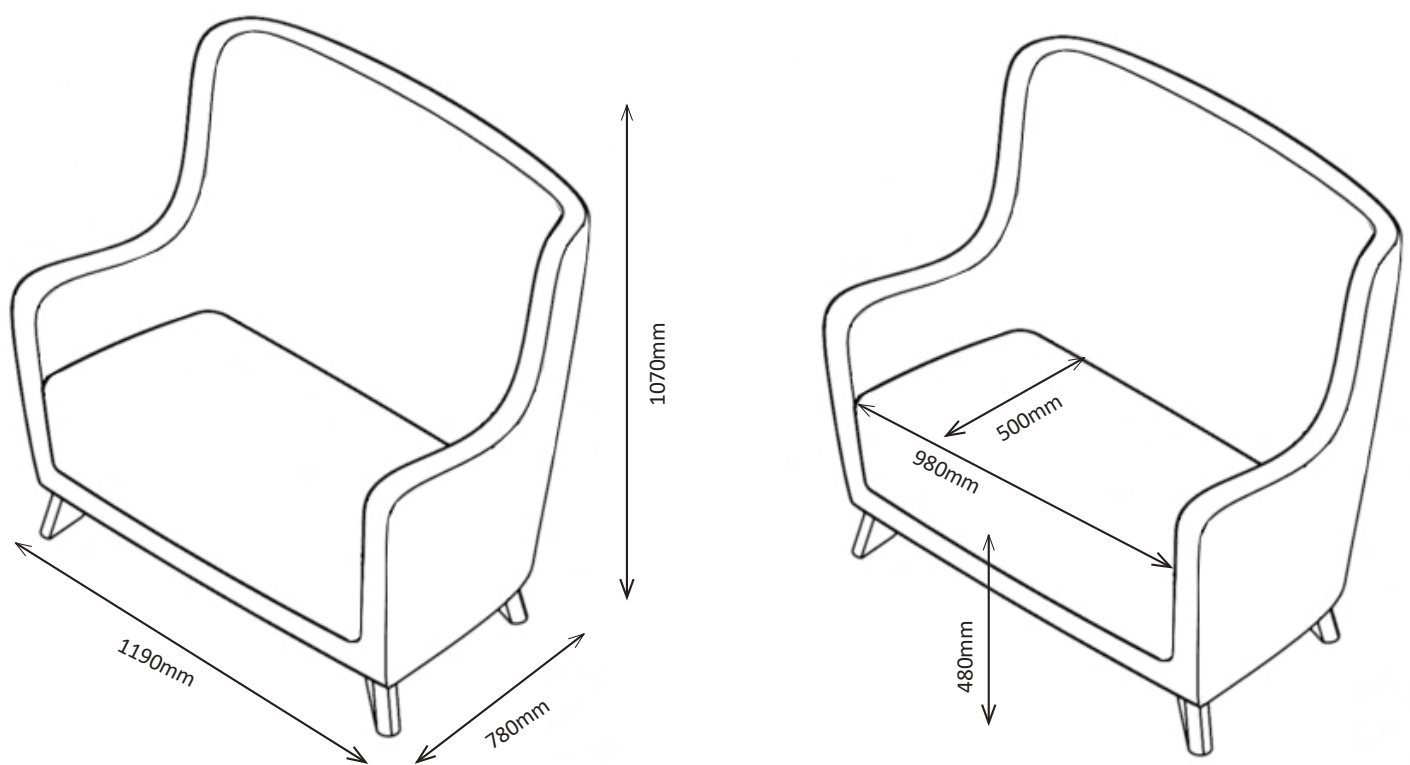

PURL PLUS LOW BACK 2-SEATER

1PULP2-400

870H | 1190W | 780D (mm)

Seat Height: 480mm

Weight: 52.5kg



UK Registered Design No. 6131291 / 6131292 / 6131293 / 6131294



KEY FEATURES

- Additional weight for added safety
- Wrap-around design of the seat back provides comfort and support
- 480mm seat height designed to help those with reduced mobility
- Fixed seat cushion to deter misuse
- Fully enclosed base with inaccessible fixings to prevent tampering
- Seat static weight tested to 200kg

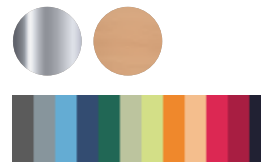

MATERIAL/FABRICATION

Our Purl Plus range has additional weight and reinforcement and has a fully enclosed base to deter tampering. Other features include a fixed seat cushion to deter misuse. 480mm seat height has been designed to help those with reduced mobility. Fixed upholstered cushioned seat is made from fire retardant, CMHR (combustion modified high resilience) foam is safe for both users and staff. Chrome metal feet (height: 120mm) gives the range a modern and clean appearance.

TEST STANDARDS

- Strength and stability tested to BS EN 16139:2013 (Test level 2 - general use)
- Fabrics fire retardancy - BS 7176:2007 Source 5
- Seat static weight tested to 200kg

OPTIONS

- Also available as a standard Purl range
- Also available as a Purl Plus armchair option
- Available as Purl Plus high back 2-Seater (see below)

1PUHP2-400
1070H | 1190W | 780D (mm)
Seat Height: 480mm
Weight: 56.5kg



FINISH

Available with chrome or natural wood feet

FABRICS

Available in a wide choice of fabrics including Vinyl, Waterproof, Non Waterproof and Leather

ASSEMBLY

Arrives assembled and ready to use

DELIVERY

INSTALLATION/FITTING

No fitting required

MAINTENANCE

See our care guidelines for more information

WARRANTY

7 year guarantee (does not include fabrics)

PURL PLUS LOW BACK 2-SEATER

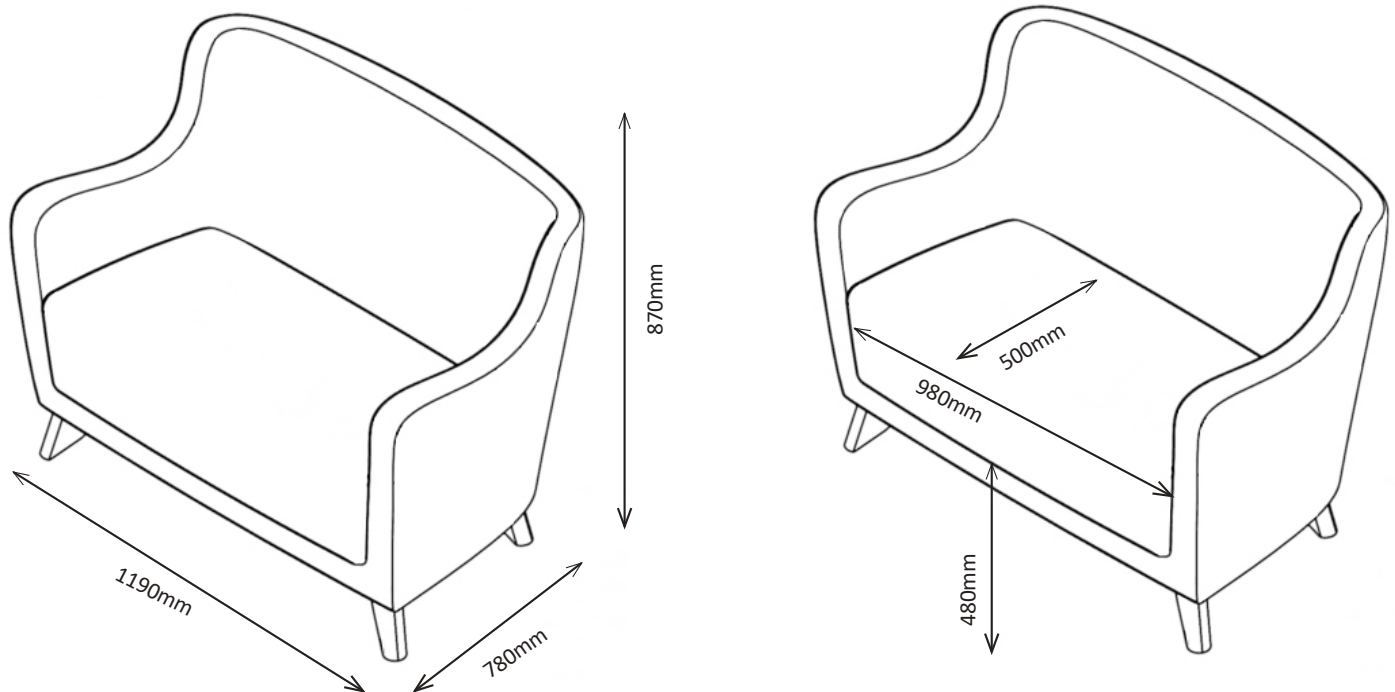

SKYE CHAIR

1SKY1-200

825 H | 735 W | 785 D (mm)

Seat Height: 400mm

Weight: 27kg



KEY FEATURES

- Strong plywood reinforcement to seat
- Tapered base design to make standing easier
- Compact design and small footprint maximises space



MATERIAL/FABRICATION

Model made from plywood with solid wooden feet. Strong plywood reinforced seat platform for added security. Interior made from fire retardant, CMHR (combustion modified high resilience) foam is safe for both users and staff

TEST STANDARDS

- Fire retardant to BS7176:2007 source 5
- Strength and stability tested to BS EN 16139:2013 (seat and back durability tested for 200,000 cycles)

OPTIONS

- Also available as a plus model
- Available as an armchair and 2-Seater
- Optional plinth base - prevents dust and dirt from gathering underneath

COLOUR/FINISH

Feet come in Natural as standard

FABRIC

Available in a wide choice of fabrics including Vinyl, Waterproof, Non Waterproof and Leather

ASSEMBLY

Arrives assembled and ready to use

DELIVERY

INSTALLATION/FITTING

No fitting required

MAINTENANCE

See our care guidelines for more information

WARRANTY

7 year guarantee (does not include fabrics)

SKYE PLUS CHAIR

1SKYP1-400

825H | 735W | 785D (mm)

Seat Height: 400mm

Weight: 40kg



KEY FEATURES

- Strong plywood frame with additional reinforcement ensures maximum strength
- Tapered base design to make standing easier
- Compact design and small footprint maximises space
- Heavyweight to deter mishandling
- Seat static weight tested to 500kg



MATERIAL/FABRICATION

Heavyweight model made from plywood and solid wood feet assembled using anti-tamper fixings to deter misuse. Strong plywood reinforcement and anti-stash enclosed base as standard. Interior made from fire retardant, CMHR (combustion modified high resilience) foam is safe for both users and staff

TEST STANDARDS

- Fire retardant to BS7176:2007 source 5
- Strength and stability tested to BS EN 16139:2013 (seat and back durability tested for 200,000 cycles)
- Seat static weight tested to 500kg

OPTIONS

- Also available as a standard model
- Available as an armchair and 2-Seater
- Optional plinth base - prevents dust and dirt from gathering underneath

COLOUR/FINISH

Feet come in Natural as standard

FABRIC

Available in a wide choice of fabrics including Vinyl, Waterproof, Non Waterproof and Leather

ASSEMBLY

Arrives assembled and ready to use

DELIVERY

INSTALLATION/FITTING

No fitting required

MAINTENANCE

See our care guidelines for more information

WARRANTY

7 year guarantee (does not include fabrics)

SKYE 2-SEATER

1SKY2-200

825 H | 1250 W | 785 D (mm)

Seat Height: 400mm

Weight: 39kg



KEY FEATURES

- Strong plywood reinforcement to seat
- Tapered base design to make standing easier
- Compact design and small footprint maximises space



MATERIAL/FABRICATION

Model made from plywood with solid wooden feet. Strong plywood reinforced seat platform for added security. Interior made from fire retardant, CMHR (combustion modified high resilience) foam is safe for both users and staff

TEST STANDARDS

- Fire retardant to BS7176:2007 source 5
- Strength and stability tested to BS EN 16139:2013 (seat and back durability tested for 200,000 cycles)

OPTIONS

- Also available as a plus model
- Available as an armchair and 2-Seater
- Optional plinth base - prevents dust and dirt from gathering underneath

COLOUR/FINISH

Feet come in Natural as standard

FABRIC

Available in a wide choice of fabrics including Vinyl, Waterproof, Non Waterproof and Leather

ASSEMBLY

Arrives assembled and ready to use

DELIVERY

INSTALLATION/FITTING

No fitting required

MAINTENANCE

See our care guidelines for more information

WARRANTY

7 year guarantee (does not include fabrics)

SKYE PLUS 2-SEATER

1SKYP2-400

825H | 1250W | 785D (mm)

Seat Height: 400mm

Weight: 58kg



KEY FEATURES

- Strong plywood frame with additional reinforcement ensures maximum strength
- Tapered base design to make standing easier
- Compact design and small footprint maximises space
- Heavyweight to deter mishandling
- Seat static weight tested to 500kg



MATERIAL/FABRICATION

Heavyweight model made from plywood and solid wood feet assembled using anti-tamper fixings to deter misuse. Strong plywood reinforcement and anti-stash enclosed base as standard. Interior made from fire retardant, CMHR (combustion modified high resilience) foam is safe for both users and staff

TEST STANDARDS

- Fire retardant to BS7176:2007 source 5
- Strength and stability tested to BS EN 16139:2013 (seat and back durability tested for 200,000 cycles)
- Seat static weight tested to 500kg

OPTIONS

- Also available as a standard model
- Available as an armchair and 2-Seater
- Optional plinth base - prevents dust and dirt from gathering underneath

COLOUR/FINISH

Feet come in Natural as standard

FABRIC

Available in a wide choice of fabrics including Vinyl, Waterproof, Non Waterproof and Leather

ASSEMBLY

Arrives assembled and ready to use

DELIVERY

INSTALLATION/FITTING

No fitting required

MAINTENANCE

See our care guidelines for more information

WARRANTY

7 year guarantee (does not include fabrics)

TEMPO CHAIR

1TM1-100

735H | 715W | 730D (mm)

Seat Height: 400mm

Weight: 22.5kg



KEY FEATURES

- Comfortable wrap-round back
- Fixed cushion prevents misuse
- Tough and sturdy wooden feet

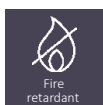

MATERIAL/FABRICATION

Solid beech frame with plywood and MFC components. All cushioned areas are fixed to the base to deter misuse. Interior made from fire retardant, CMHR (combustion modified high resilience) foam

TEST STANDARDS

- All fabrics fire retardant to BS7176:2007 source 5
- Strength and stability tested to BS EN 16139:2013 (seat and back durability tested for 200,000 cycles)

OPTIONS

- Also available as reinforced, weighted Tempo Plus-
- Removable seat cushion for easy cleaning

COLOUR/FINISH

Feet come in Natural as standard

FABRIC

Available in a wide choice of fabrics including Vinyl, Waterproof, Non Waterproof and Leather

ASSEMBLY

Arrives assembled and ready to use

DELIVERY

INSTALLATION/FITTING

No fitting required

MAINTENANCE

See upholstered furniture section of our care guidelines for fabric care instructions

WARRANTY

7 year guarantee (does not include fabrics)

TEMPO PLUS CHAIR

TTP1-400

735H | 715W | 730D (mm)

Seat Height: 400mm

Weight: 38kg



KEY FEATURES

- Strong timber frame with additional reinforcement ensures maximum strength
- Enclosed base minimises concealment
- Fixed cushion prevents misuse
- Heavyweight to deter mishandling
- Seat static weight tested to 200kg

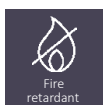

MATERIAL/FABRICATION

Heavyweight, durable (seat and back tested for 200,000 cycles) model made from plywood and solid wood feet assembled using anti-tamper fixings to deter misuse. Strong (tested to BS EN 16139:2013 Level 2) plywood reinforcement. All cushioned areas are fixed to the base to deter misuse. Interior made from fire retardant, CMHR (combustion modified high resilience) foam is safe for both users and staff

TEST STANDARDS

- Fire retardant to BS7176:2007 source 5
- Strength and stability tested to BS EN 16139:2013 (seat and back durability tested for 200,000 cycles)

OPTIONS

- Also available as a standard model
- Removable seat cushion for easy cleaning

COLOUR/FINISH

Feet come in Natural as standard

FABRIC

Available in a wide choice of fabrics including Vinyl, Waterproof, Non Waterproof and Leather

ASSEMBLY

Arrives assembled and ready to use

DELIVERY

INSTALLATION/FITTING

No fitting required

MAINTENANCE

See upholstered furniture section of our care guidelines for fabric care instructions

WARRANTY

7 year guarantee (does not include fabrics)

TEMPO 2-SEATER

1TM2-100

735H | 1400W | 730D (mm)

Seat Height: 400mm

KEY FEATURES

- Comfortable wrap-round back
- Fixed cushion prevents misuse
- Tough and sturdy wooden feet

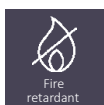

MATERIAL/FABRICATION

Solid beech frame with plywood and MFC components. All cushioned areas are fixed to the base to deter misuse. Interior made from fire retardant, CMHR (combustion modified high resilience) foam.

TEST STANDARDS

- All fabrics fire retardant to BS7176:2007 source 5
- Strength and stability tested to BS EN 16139:2013 (seat and back durability tested for 200,000 cycles)

OPTIONS

- Also available as reinforced, weighted Tempo Plus-
- Removable seat cushion for easy cleaning

COLOUR/FINISH

Feet come in Natural as standard

FABRIC

Available in a wide choice of fabrics including Vinyl, Waterproof, Non Waterproof and Leather

ASSEMBLY

Arrives assembled and ready to use

DELIVERY

INSTALLATION/FITTING

No fitting required

MAINTENANCE

See upholstered furniture section of our care guidelines for fabric care instructions

WARRANTY

7 year guarantee (does not include fabrics)

TEMPO PLUS 2-SEATER

1TP2-400

735H | 1400W | 730D (mm)

Seat Height: 400mm

Weight: 76kg

KEY FEATURES

- Strong timber frame with additional reinforcement ensures maximum strength
- Enclosed base minimises concealment
- Fixed cushion prevents misuse
- Heavyweight to deter mishandling
- Seat static weight tested to 200kg

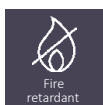

MATERIAL/FABRICATION

Heavyweight, durable (seat and back tested for 200,000 cycles) model made from plywood and solid wood feet assembled using anti-tamper fixings to deter misuse. Strong (tested to BS EN 16139:2013 Level 2) plywood reinforcement. All cushioned areas are fixed to the base to deter misuse. Interior made from fire retardant, CMHR (combustion modified high resilience) foam is safe for both users and staff

TEST STANDARDS

- Fire retardant to BS7176:2007 source 5
- Strength and stability tested to BS EN 16139:2013 (seat and back durability tested for 200,000 cycles)

OPTIONS

- Also available as a standard model
- Removable seat cushion for easy cleaning

COLOUR/FINISH

Feet come in Natural as standard

FABRIC

Available in a wide choice of fabrics including Vinyl, Waterproof, Non Waterproof and Leather

ASSEMBLY

Arrives assembled and ready to use

DELIVERY

INSTALLATION/FITTING

No fitting required

MAINTENANCE

See upholstered furniture section of our care guidelines for fabric care instructions

WARRANTY

7 year guarantee (does not include fabrics)

ZEN PLUS ROCKER

1ZENRP1-900

1015H | 660W | 1115D (mm)

Weight: 59kg



UK Registered Design No. 6131314



KEY FEATURES

- Fluid rocking motion provides a source of focus and calm
- Smoothly reclined shape prevents pressure points and provides comfort
- Evenly distributed additional weight to prevent overturning
- Plywood reinforcement for added durability
- Seat static weight tested to 500kg



MATERIAL/FABRICATION

During periods of stress or anxiety, some of us may find ourselves engaging in repetitive movements like fingerdrumming or leg-bouncing as a form of release. But for those living on the autism spectrum, repetitive movements are often part of everyday life. Rocking back and forth can help to minimise the impact of outside stimuli, providing a source of focus, and in turn, a feeling of calm. Interior made from CMHR (combustion modified high resilience) foam to ensure maximum support, durability and comfort.

The curved plywood ski is finished in matt lacquer with white pigment. Security screws are recessed into the plywood so they do not damage the floor surface. Anti-stash seams helps prevent concealment opportunities.

TEST STANDARDS

- BS EN 16139:2013 (Test level 2 - general use)
- Fabrics fire retardant to BS7176:2007 source 5

OPTIONS

- Available with fixed arms only
- Plywood base Birch finish only
- Can be upholstered in 2 fabrics for added personalisation
- Other products are available in the [Zen](#) and [Zen Plus](#) ranges

FABRIC

A wide choice of upholstery including water-resistant vinyl and fabrics.

ASSEMBLY

Arrives assembled and ready to use

DELIVERY

INSTALLATION/FITTING

No fitting required

MAINTENANCE

See upholstered furniture section of our care guidelines

WARRANTY

7 year guarantee (does not include fabrics)

ZEN CHAIR

1ZEN1-120

1000 H | 600 W | 1485 D (mm)

Seat Height: 310 mm

Weight: 32kg



KEY FEATURES

- Ergonomically designed chair to prevent rapid standing motion
- Full plywood reinforcement ensures extra strength and stability
- Smoothly reclined shape prevents pressure points and provides exceptional comfort



MATERIAL/FABRICATION

Full plywood structure and additional reinforcement offer strength and stability. Shaped to create areas of calm, relaxation and rest with design preventing rapid standing motion. Interior made from CMHR (combustion modified high resilience) foam to ensure maximum support, durability and comfort.

TEST STANDARDS

- BS EN 15373:2007 (Test level 2 - general use)
- Fabrics fire retardant to BS7176:2007 source 5, UL94 HB and BS 5852:2006 ignition source 5

OPTIONS

- Weighted option available
- Can be upholstered in 2 fabrics (as shown) for added personalisation

FABRIC

A wide choice of upholstery including water-resistant vinyl and fabrics

ASSEMBLY

Arrives assembled and ready to use

DELIVERY

INSTALLATION/FITTING

No fitting required

MAINTENANCE

See upholstered furniture section of our care guidelines

WARRANTY

7 year guarantee (does not include fabrics)

ZEN PLUS CHAIR

1ZENP1-400

1000H | 600W | 1485D (mm)

Seat Height: 310 mm

Weight: 61.5kg



KEY FEATURES

- Plywood reinforcement, including a fully enclosed base to prevent concealment
- Designed to prevent rapid standing motion, creating a safer and calmer environment
- Smoothly reclined shape prevents pressure points and provides exceptional comfort
- Weighted to deter mishandling
- Seat static weight tested to 500kg



MATERIAL/FABRICATION

Full plywood structure and additional reinforcement offer strength and stability. Shaped to create areas of calm, relaxation and rest with design preventing rapid standing motion. Interior made from CMHR (combustion modified high resilience) foam to ensure maximum support, durability and comfort.

TEST STANDARDS

- BS EN 15373:2007 (Test level 2 - general use)
- Fabrics fire retardant to BS7176:2007 source 5, UL94 HB and BS 5852:2006 ignition source 5

OPTIONS

- Also available as a standard model
- Can be upholstered in dual fabrics (as shown) for added personalisation

FABRIC

A wide choice of upholstery including water-resistant vinyl and fabrics

ASSEMBLY

Arrives assembled and ready to use

DELIVERY

INSTALLATION/FITTING

No fitting required

MAINTENANCE

See our care guidelines for more information

WARRANTY

7 year guarantee (does not include fabrics)

ZEN DUO CHAIR

1ZEND-120

1000 H | 600 W | 990D (mm)

Seat Height: 310 mm

Weight: 26.5kg



KEY FEATURES

- Ergonomically designed chair and stool to prevent rapid standing motion
Perfect reclined shape prevents
- pressure points and provides exceptional comfort
- Smoothly reclined shape prevents pressure points and provides exceptional comfort



MATERIAL/FABRICATION

Full plywood structure and additional reinforcement offer strength and stability. Shaped to create areas of calm, relaxation and rest with design preventing rapid standing motion. Interior made from CMHR (combustion modified high resilience) foam to ensure maximum support, durability and comfort.

TEST STANDARDS

- BS EN 15373:2007 (Test level 2 - general use)
Fabrics fire retardant to BS7176:2007 source 5,
- UL94 HB and BS 5852:2006 ignition source 5

OPTIONS

- Can be upholstered in 2 fabrics (as shown) for added personalisation
- Also available with matching footstool (as shown)

1ZENDS-120
450 H | 540 W | 545 D (mm)
Weight: 13kg



FABRIC

A wide choice of upholstery including water-resistant vinyl and fabrics

ASSEMBLY

Arrives assembled and ready to use

DELIVERY

INSTALLATION/FITTING

No fitting required

MAINTENANCE

See upholstered furniture section of our care guidelines

WARRANTY

7 year guarantee (does not include fabrics)

ZEN PLUS DUO CHAIR

1ZENDP-400

1000H | 600W | 990D (mm)

Seat Height: 310mm

Weight: 41.5kg

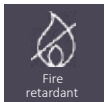

KEY FEATURES

- Plywood reinforcement, including a fully enclosed base to prevent concealment
- Designed to prevent rapid standing motion, creating a safer and calmer environment
- Smoothly reclined shape prevents pressure points and provides exceptional comfort
- Weighted to deter mishandling
- Seat static weight tested to 500kg



MATERIAL/FABRICATION

Full plywood structure and additional reinforcement offer strength and stability. Shaped to create areas of calm, relaxation and rest with design preventing rapid standing motion. Interior made from CMHR (combustion modified high resilience) foam to ensure maximum support, durability and comfort.

TEST STANDARDS

- BS EN 15373:2007 (Test level 2 - general use)
- Fabrics fire retardant to BS7176:2007 source 5, UL94 HB and BS 5852:2006 ignition source 5

OPTIONS

- Also available as a standard model
- Can be upholstered in dual fabrics (as shown) for added personalisation
- Also available with matching footstool (see below)

1ZENDSP-400
450H | 540W | 545D (mm)
Weight: 23kg



FABRIC

A wide choice of upholstery including water-resistant vinyl and fabrics

ASSEMBLY

Arrives assembled and ready to use

DELIVERY

INSTALLATION/FITTING

No fitting required

MAINTENANCE

See upholstered furniture section of our care guidelines

WARRANTY

7 year guarantee (does not include fabrics)

SNUG CHAIR

1SG1-100

890H | 940W | 1060D (mm)

Seat height: 450mm

Weight: 30kg



KEY FEATURES

- Combines sumptuous comfort with durable reinforcement
- Versatile modular design helps you make the most of your space
- Promotes social inclusion
- Low overall height provides clearer sight lines for staff

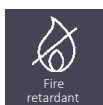

MATERIAL/FABRICATION

Soft, deep foam used for excellent comfort. Modular design allows pieces to be used individually or in multiples to create an arrangement to best suit any space. No-arm design aids de-escalation and low overall height provides clearer sightlines for staff. Interior made from fire retardant, CMHR (combustion modified high resilience) foam is safe for both users and staff.

TEST STANDARDS

- Strength and stability tested to BS EN 16139:2013 level 2 (seat and back durability tested for 200,000 cycles)
- Fire retardant to CAL 133 and UL 94 HB

OPTIONS

- Optional linking bracket if using in multiples
- Also available in a Plus model with additional reinforcement

COLOUR/FINISH

Black plastic feet as standard

FABRIC

A wide choice of upholstery including water-resistant vinyl and fabrics

ASSEMBLY

Arrives assembled and ready to use

DELIVERY

INSTALLATION/FITTING

No fitting required

MAINTENANCE

See upholstered furniture section of our care guidelines

WARRANTY

7 year guarantee (does not include fabrics)



KEY FEATURES

- Combines sumptuous comfort with durable reinforcement
- Versatile modular design helps you make the most of your space
- Promotes social inclusion
- Low overall height provides clearer sight lines for staff



MATERIAL/FABRICATION

Soft, deep foam used for excellent comfort. Modular design allows pieces to be used individually or in multiples to create an arrangement to best suit any space. No-arm design aids de-escalation and low overall height provides clearer sightlines for staff. Interior made from fire retardant, CMHR (combustion modified high resilience) foam is safe for both users and staff.

TEST STANDARDS

- Strength and stability tested to BS EN 16139:2013 level 2 (seat and back durability tested for 200,000 cycles)
- Fire retardant to CAL 133 and UL 94 HB

OPTIONS

- Optional linking bracket if using in multiples
- Also available in a Plus model with additional reinforcement

COLOUR/FINISH

Black plastic feet as standard

FABRIC

A wide choice of upholstery including water-resistant vinyl and fabrics

ASSEMBLY

Arrives assembled and ready to use

DELIVERY

INSTALLATION/FITTING

No fitting required

MAINTENANCE

See upholstered furniture section of our care guidelines

WARRANTY

7 year guarantee (does not include fabrics)

SNUG FOOTSTOOL

1SGS-100

400H | 900W | 900D (mm)

Seat height: 450mm



KEY FEATURES

- Combines sumptuous comfort with durable reinforcement
- Versatile modular design helps you make the most of your space
- Promotes social inclusion



MATERIAL/FABRICATION

Soft, deep foam used for excellent comfort. Modular design allows pieces to be used individually or in multiples to create an arrangement to best suit any space. No-arm design aides de-escalation and low overall height provides clearer sightlines for staff. Interior made from fire retardant, CMHR (combustion modified high resilience) foam is safe for both users and staff.

TEST STANDARDS

- Strength and stability tested to BS EN 16139:2013 level 2 (seat and back durability tested for 200,000 cycles)
- Fire retardant to CAL 133 and UL 94 HB

OPTIONS

- Also available in a Plus model with additional reinforcement

COLOUR/FINISH

Black plastic feet as standard

FABRIC

A wide choice of upholstery including water-resistant vinyl and fabrics

ASSEMBLY

Arrives assembled and ready to use

DELIVERY

INSTALLATION/FITTING

No fitting required

MAINTENANCE

See upholstered furniture section of our care guidelines

WARRANTY

7 year guarantee (does not include fabrics)

SNUG PLUS CHAIR

1SGP1-400

890H | 940W | 1060D (mm)

Seat height: 450mm

Weight: 40kg



KEY FEATURES

- Plywood reinforcement, including a fully enclosed base to prevent concealment
- Versatile modular design helps you make the most of your space
- Promotes social inclusion
- Low overall height provides clearer sight lines for staff
- Seat static weight tested to 500kg



MATERIAL/FABRICATION

Carcass made from a mix of particle board and plywood with walnut feet, fully reinforced with plywood for extra strength (tested to BS EN 16139:2013 level 2). All cushioned areas are fixed to the base to ensure that they are not taken off. Interior made from fire retardant, CMHR (combustion modified high resilience) foam is safe for both users and staff.

TEST STANDARDS

- Strength and stability tested to BS EN 16139:2013 level 2 (seat and back durability tested for 200,000 cycles)
- Fire retardant to CAL 133 and UL 94 HB

OPTIONS

- Optional linking bracket if using in multiples
- Also available in standard (non Plus) model

COLOUR/FINISH

Black plastic feet as standard

FABRIC

A wide choice of upholstery including water-resistant vinyl and fabrics

ASSEMBLY

Arrives assembled and ready to use

DELIVERY

INSTALLATION/FITTING

No fitting required

MAINTENANCE

See upholstered furniture section of our care guidelines

WARRANTY

7 year guarantee (does not include fabrics)

SNUG PLUS CORNER CHAIR

1SGPC1-400

890H | 1060W | 1060D (mm)

Seat height: 450mm

Weight: 53kg

KEY FEATURES



- Plywood reinforcement, including a fully enclosed base to prevent concealment
- Versatile modular design helps you make the most of your space
- Promotes social inclusion
- Low overall height provides clearer sight lines for staff
- Seat static weight tested to 500kg



MATERIAL/FABRICATION

Carcass made from a mix of particle board and plywood with walnut feet, fully reinforced with plywood for extra strength (tested to BS EN 16139:2013 level 2). All cushioned areas are fixed to the base to ensure that they are not taken off. Interior made from fire retardant, CMHR (combustion modified high resilience) foam is safe for both users and staff.

TEST STANDARDS

- Strength and stability tested to BS EN 16139:2013 level 2 (seat and back durability tested for 200,000 cycles)
- Fire retardant to CAL 133 and UL 94 HB

OPTIONS

- Optional linking bracket if using in multiples
- Also available in standard (non Plus) model

COLOUR/FINISH

Black plastic feet as standard

FABRIC

A wide choice of upholstery including water-resistant vinyl and fabrics

ASSEMBLY

Arrives assembled and ready to use

DELIVERY

INSTALLATION/FITTING

No fitting required

MAINTENANCE

See upholstered furniture section of our care guidelines

WARRANTY

7 year guarantee (does not include fabrics)

SNUG PLUS FOOTSTOOL

1SGPS-400

400H | 900W | 900D (mm)

Weight: 26.5kg

KEY FEATURES

- Plywood reinforcement, including a fully enclosed base to prevent concealment
- Versatile modular design helps you make the most of your space
- Promotes social inclusion
- Seat static weight tested to 500kg



MATERIAL/FABRICATION

Carcass made from a mix of particle board and plywood with walnut feet, fully reinforced with plywood for extra strength (tested to BS EN 16139:2013 level 2). All cushioned areas are fixed to the base to ensure that they are not taken off. Interior made from fire retardant, CMHR (combustion modified high resilience) foam is safe for both users and staff.

TEST STANDARDS

- Strength and stability tested to BS EN 16139:2013 lvl 2 (seat and back durability tested for 200,000 cycles)
- Fire retardant to CAL 133 and UL 94 HB

OPTIONS

- Optional linking bracket if using in multiples
- Also available in standard (non Plus) model

COLOUR/FINISH

Black plastic feet as standard

FABRIC

A wide choice of upholstery including water-resistant vinyl and fabrics

ASSEMBLY

Arrives assembled and ready to use

DELIVERY

INSTALLATION/FITTING

No fitting required

MAINTENANCE

See upholstered furniture section of our care guidelines

WARRANTY

7 year guarantee (does not include fabrics)

MAGNA CHAIR

1MA1-200

780H | 970W | 860D (mm)

Seat Height: 420mm

Weight: 45kg



KEY FEATURES

- Reinforced seat platform as standard for improved durability
- Our best selling sofa range
- Fixed seat and back cushions to prevent misuse
- Strength and stability tested for severe contract use



MATERIAL/FABRICATION

Carcass made from a mix of particle board and plywood with solid beech wood feet for standard reinforcement. Plus range reinforcement options further offer high levels of durability and strength. All cushions fixed to the base to ensure that they are not taken off with anti-stash seams option to prevent hiding of contraband. Cushioned areas made from fire retardant, CMHR (combustion modified high resilience) foam is safe for both users and staff

TEST STANDARDS

- Fire retardant to BS7176:2007 source 5
- Strength and stability tested to BS 7945: 1999

OPTIONS

- Available in Standard or Plus levels or reinforcement
- Optional plinth base prevents dust and dirt gathering underneath

COLOUR/FINISH

Feet available in Natural or Walnut

FABRIC

Available in a wide choice of fabrics including Vinyl, Waterproof, Non Waterproof and Leather

ASSEMBLY

Arrives assembled and ready to use

DELIVERY

INSTALLATION/FITTING

No fitting required

MAINTENANCE

See upholstered furniture section of our care guidelines

WARRANTY

7 year guarantee (does not include fabrics)

MAGNA 2-SEATER

1MA2-200

780H | 1480W | 860D (mm)

Seat Height: 420mm

Weight: 57kg



KEY FEATURES

- Reinforced seat platform as standard for improved durability
- Our best selling sofa range
- Fixed seat and back cushions to prevent misuse
- Strength and stability tested for severe contract use



MATERIAL/FABRICATION

Carcass made from a mix of particle board and plywood with solid beech wood feet for standard reinforcement. Plus range reinforcement options further offer high levels of durability and strength. All cushions fixed to the base to ensure that they are not taken off with anti-stash seams option to prevent hiding of contraband. Cushioned areas made from fire retardant, CMHR (combustion modified high resilience) foam is safe for both users and staff

TEST STANDARDS

- Fire retardant to BS7176:2007 source 5
- Strength and stability tested to BS 7945: 1999

OPTIONS

- Available in Standard or Plus levels or reinforcement
- Optional plinth base prevents dust and dirt gathering underneath

COLOUR/FINISH

Feet available in Natural or Walnut

FABRIC

Available in a wide choice of fabrics including Vinyl, Waterproof, Non Waterproof and Leather

ASSEMBLY

Arrives assembled and ready to use

DELIVERY

INSTALLATION/FITTING

No fitting required

MAINTENANCE

See upholstered furniture section of our care guidelines

WARRANTY

7 year guarantee (does not include fabrics)

MAGNA 3-SEATER

1MA3-200

780H | 2010W | 860D (mm)

Seat Height: 420mm

Weight: 67kg



KEY FEATURES

- Reinforced seat platform as standard for improved durability
- Our best selling sofa range
- Fixed seat and back cushions to prevent misuse
- Strength and stability tested for severe contract use



MATERIAL/FABRICATION

Carcass made from a mix of particle board and plywood with solid beech wood feet for standard reinforcement. Plus range reinforcement options further offer high levels of durability and strength. All cushions fixed to the base to ensure that they are not taken off with anti-stash seams option to prevent hiding of contraband. Cushioned areas made from fire retardant, CMHR (combustion modified high resilience) foam is safe for both users and staff

TEST STANDARDS

- Fire retardant to BS7176:2007 source 5
- Strength and stability tested to BS 7945: 1999

OPTIONS

- Available in Standard or Plus levels or reinforcement
- Optional plinth base prevents dust and dirt gathering underneath

COLOUR/FINISH

Feet available in Natural or Walnut

FABRIC

Available in a wide choice of fabrics including Vinyl, Waterproof, Non Waterproof and Leather

ASSEMBLY

Arrives assembled and ready to use

DELIVERY

INSTALLATION/FITTING

No fitting required

MAINTENANCE

See upholstered furniture section of our care guidelines

WARRANTY

7 year guarantee (does not include fabrics)

MAGNA PLUS CHAIR

1MA1-400

780H | 970W | 860D (mm)

Seat Height: 420mm

Weight: 55kg



KEY FEATURES

- Plywood reinforcement for added strength
- Fully enclosed base to prevent concealment
- Fixed seat and back cushions to prevent misuse
- Strength and stability tested for severe contract use
- Seat static weight tested to 500kg



MATERIAL/FABRICATION

Carcass made from a mix of particle board and plywood with solid beech wood feet. Strong plywood reinforcement offers excellent levels of durability and strength. All cushions fixed to the base to ensure that they are not taken off with anti-stash seams option to prevent hiding of contraband. Cushioned areas made from fire retardant, CMHR (combustion modified high resilience) foam is safe for both users and staff

TEST STANDARDS

- Fire retardant to BS7176:2007 source 5
- Strength and stability tested to BS 7945: 1999
- Strength and stability tested to BS EN 15373:2007

OPTIONS

- Available in Standard or Plus levels or reinforcement
- Optional “zero depth seams” to prevent concealment
- Optional plinth base prevents dust and dirt gathering underneath

COLOUR/FINISH

Feet available in Natural or Walnut

FABRIC

Available in a wide choice of fabrics including Vinyl, Waterproof, Non Waterproof and Leather

ASSEMBLY

Arrives assembled and ready to use

DELIVERY

INSTALLATION/FITTING

No fitting required

MAINTENANCE

See upholstered furniture section of our care guidelines

WARRANTY

7 year guarantee (does not include fabrics)

MAGNA PLUS 2-SEATER

1MA2-400

780H | 1480W | 860D (mm)

Seat Height: 420mm

Weight: 75kg

KEY FEATURES

- Plywood reinforcement for added strength
- Fully enclosed base to prevent concealment
- Fixed seat and back cushions to prevent misuse
- Strength and stability tested for severe contract use
- Seat static weight tested to 500kg



MATERIAL/FABRICATION

Carcass made from a mix of particle board and plywood with solid beech wood feet. Strong plywood reinforcement offers excellent levels of durability and strength. All cushions fixed to the base to ensure that they are not taken off with anti-stash seams option to prevent hiding of contraband. Cushioned areas made from fire retardant, CMHR (combustion modified high resilience) foam is safe for both users and staff

TEST STANDARDS

- Fire retardant to BS7176:2007 source 5
- Strength and stability tested to BS 7945: 1999
- Strength and stability tested to BS EN 15373:2007

OPTIONS

- Available in Standard or Plus levels or reinforcement
- Optional “zero depth seams” to prevent concealment
- Optional plinth base prevents dust and dirt gathering underneath

COLOUR/FINISH

Feet available in Natural or Walnut

FABRIC

Available in a wide choice of fabrics including Vinyl, Waterproof, Non Waterproof and Leather

ASSEMBLY

Arrives assembled and ready to use

DELIVERY

INSTALLATION/FITTING

No fitting required

MAINTENANCE

See upholstered furniture section of our care guidelines

WARRANTY

7 year guarantee (does not include fabrics)

MAGNA PLUS 3-SEATER

1MA3-400

780H | 2010W | 860D (mm)

Seat Height: 420mm

Weight: 103kg

KEY FEATURES

- Plywood reinforcement for added strength
- Fully enclosed base to prevent concealment
- Fixed seat and back cushions to prevent misuse
- Strength and stability tested for severe contract use
- Seat static weight tested to 500kg



MATERIAL/FABRICATION

Carcass made from a mix of particle board and plywood with solid beech wood feet. Strong plywood reinforcement offers excellent levels of durability and strength. All cushions fixed to the base to ensure that they are not taken off with anti-stash seams option to prevent hiding of contraband. Cushioned areas made from fire retardant, CMHR (combustion modified high resilience) foam is safe for both users and staff

TEST STANDARDS

- Fire retardant to BS7176:2007 source 5
- Strength and stability tested to BS 7945: 1999
- Strength and stability tested to BS EN 15373:2007

OPTIONS

- Available in Standard or Plus levels or reinforcement
- Optional “zero depth seams” to prevent concealment
- Optional plinth base prevents dust and dirt gathering underneath

COLOUR/FINISH

Feet available in Natural or Walnut

FABRIC

Available in a wide choice of fabrics including Vinyl, Waterproof, Non Waterproof and Leather

ASSEMBLY

Arrives assembled and ready to use

DELIVERY

INSTALLATION/FITTING

No fitting required

MAINTENANCE

See upholstered furniture section of our care guidelines

WARRANTY

7 year guarantee (does not include fabrics)

OHIO CHAIR

10H1-100

860H | 580W | 860D (mm)

Seat Height: 480mm

Weight: 34kg



KEY FEATURES

- Standard reinforcement provides strength and durability
- Versatile modular design helps you make the most of your space
- Ski feet protect flooring and facilitate movement



MATERIAL/FABRICATION

Carcass made from a mix of particle board and plywood with wood veneer feet, standard reinforced with plywood and ski foot designed to facilitate movement for use in multiples, if required, while also protecting flooring beneath. Gap left between base and floor to allow for easier cleaning and inspections. All cushioned areas are fixed to the base to ensure that they are not taken off and are made from fire retardant, CMHR (combustion modified high resilience) foam

TEST STANDARDS

- Fire retardant to BS 7176:2007 source 5
- Strength and stability tested to BS EN 15373:2007

OPTIONS

- Also available as a Plus model for additional reinforcement
- Linking bracket to connect items

COLOUR/FINISH

Feet come in Natural as standard

FABRIC

Available in a wide choice of fabrics including Vinyl, Waterproof, Non Waterproof, Leather and Loose Cover

ASSEMBLY

Arrives assembled and ready to use

DELIVERY

INSTALLATION/FITTING

No fitting required

MAINTENANCE

See upholstered furniture section of our care guidelines for fabric care instructions

WARRANTY

7 year guarantee (does not include fabrics)



KEY FEATURES

- Standard reinforcement provides strength and durability
- Versatile modular design helps you make the most of your space
- Ski feet protect flooring and facilitate movement



MATERIAL/FABRICATION

Carcass made from a mix of particle board and plywood with wood veneer feet, standard reinforced with plywood and ski foot designed to facilitate movement for use in multiples, if required, while also protecting flooring beneath. Gap left between base and floor to allow for easier cleaning and inspections. All cushioned areas are fixed to the base to ensure that they are not taken off and are made from fire retardant, CMHR (combustion modified high resilience) foam

TEST STANDARDS

- Fire retardant to BS 7176:2007 source 5
- Strength and stability tested to BS EN 15373:2007

OPTIONS

- Also available as a Plus model for additional reinforcement
- Linking bracket to connect items

COLOUR/FINISH

Feet come in Natural as standard

FABRIC

Available in a wide choice of fabrics including Vinyl, Waterproof, Non Waterproof, Leather and Loose Cover

ASSEMBLY

Arrives assembled and ready to use

DELIVERY

INSTALLATION/FITTING

No fitting required

MAINTENANCE

See upholstered furniture section of our care guidelines for fabric care instructions

WARRANTY

7 year guarantee (does not include fabrics)



KEY FEATURES

- Standard reinforcement provides strength and durability
- Versatile modular design helps you make the most of your space
- Ski feet protect flooring and facilitate movement

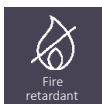

MATERIAL/FABRICATION

Carcass made from a mix of particle board and plywood with wood veneer feet, standard reinforced with plywood and ski foot designed to facilitate movement for use in multiples, if required, while also protecting flooring beneath. Gap left between base and floor to allow for easier cleaning and inspections. All cushioned areas are fixed to the base to ensure that they are not taken off and are made from fire retardant, CMHR (combustion modified high resilience) foam

TEST STANDARDS

- Fire retardant to BS 7176:2007 source 5
- Strength and stability tested to BS EN 15373:2007

OPTIONS

- Also available as a Plus model for additional reinforcement
- Linking bracket to connect items

COLOUR/FINISH

Feet come in Natural as standard

FABRIC

Available in a wide choice of fabrics including Vinyl, Waterproof, Non Waterproof, Leather and Loose Cover

ASSEMBLY

Arrives assembled and ready to use

DELIVERY

INSTALLATION/FITTING

No fitting required

MAINTENANCE

See upholstered furniture section of our care guidelines for fabric care instructions

WARRANTY

7 year guarantee (does not include fabrics)

KEY FEATURES

- Standard reinforcement provides strength and durability
- Versatile modular design helps you make the most of your space
- Ski feet protect flooring and facilitate movement



MATERIAL/FABRICATION

Carcass made from a mix of particle board and plywood with wood veneer feet, standard reinforced with plywood and ski foot designed to facilitate movement for use in multiples, if required, while also protecting flooring beneath. Gap left between base and floor to allow for easier cleaning and inspections. All cushioned areas are fixed to the base to ensure that they are not taken off and are made from fire retardant, CMHR (combustion modified high resilience) foam

TEST STANDARDS

- Fire retardant to BS 7176:2007 source 5
- Strength and stability tested to BS EN 15373:2007

OPTIONS

- Also available as a Plus model for additional reinforcement
- Linking bracket to connect items

COLOUR/FINISH

Feet come in Natural as standard

FABRIC

Available in a wide choice of fabrics including Vinyl, Waterproof, Non Waterproof, Leather and Loose Cover

ASSEMBLY

Arrives assembled and ready to use

DELIVERY

INSTALLATION/FITTING

No fitting required

MAINTENANCE

See upholstered furniture section of our care guidelines for fabric care instructions

WARRANTY

7 year guarantee (does not include fabrics)



KEY FEATURES

- Plywood reinforcement, including a fully enclosed base to prevent concealment
- Versatile modular design helps you make the most of your space
- Ski feet protect flooring and facilitate movement
- Seat static weight tested to 200kg



MATERIAL/FABRICATION

Carcass made from a mix of particle board and plywood with wood veneer feet, fully reinforced with plywood for extra strength and anti-stash enclosed base. Ski foot designed to facilitate movement for use in multiples, if required, while also protecting flooring beneath. Gap left between base and floor to allow for easier cleaning and inspections. All cushioned areas are fixed to the base to ensure that they are not taken off and are made from fire retardant, CMHR (combustion modified high resilience) foam

TEST STANDARDS

- Fire retardant to BS 7176:2007 source 5
- Strength and stability tested to BS EN 15373:2007

OPTIONS

- Also available as a standard model
- Linking bracket to connect items

COLOUR/FINISH

Feet come in Natural as standard

FABRIC

Available in a wide choice of fabrics including Vinyl, Waterproof, Non Waterproof, Leather and Loose Cover

ASSEMBLY

Arrives assembled and ready to use

DELIVERY

INSTALLATION/FITTING

No fitting required

MAINTENANCE

See upholstered furniture section of our care guidelines for fabric care instructions

WARRANTY

7 year guarantee (does not include fabrics)

OHIO PLUS CURVED CHAIR (NARROW FRONT)

10PC1-400

860H | 1030W | 860D (mm)

Seat Height: 480mm

Weight: 27.5kg



KEY FEATURES

- Plywood reinforcement, including a fully enclosed base to prevent concealment
- Versatile modular design helps you make the most of your space
- Ski feet protect flooring and facilitate movement
- Seat static weight tested to 200kg



MATERIAL/FABRICATION

Carcass made from a mix of particle board and plywood with wood veneer feet, fully reinforced with plywood for extra strength and anti-stash enclosed base. Ski foot designed to facilitate movement for use in multiples, if required, while also protecting flooring beneath. Gap left between base and floor to allow for easier cleaning and inspections. All cushioned areas are fixed to the base to ensure that they are not taken off and are made from fire retardant, CMHR (combustion modified high resilience) foam

TEST STANDARDS

- Fire retardant to BS 7176:2007 source 5
- Strength and stability tested to BS EN 15373:2007

OPTIONS

- Also available as a standard model
- Linking bracket to connect items

COLOUR/FINISH

Feet come in Natural as standard

FABRIC

Available in a wide choice of fabrics including Vinyl, Waterproof, Non Waterproof, Leather and Loose Cover

ASSEMBLY

Arrives assembled and ready to use

DELIVERY

INSTALLATION/FITTING

No fitting required

MAINTENANCE

See upholstered furniture section of our care guidelines for fabric care instructions

WARRANTY

7 year guarantee (does not include fabrics)

OHIO PLUS CURVED CHAIR (WIDE FRONT)

10PC1-500

860H | 1030W | 860D (mm)

Seat Height: 480mm

Weight: 25kg



KEY FEATURES

- Plywood reinforcement, including a fully enclosed base to prevent concealment
- Versatile modular design helps you make the most of your space
- Ski feet protect flooring and facilitate movement
- Seat static weight tested to 200kg



MATERIAL/FABRICATION

Carcass made from a mix of particle board and plywood with wood veneer feet, fully reinforced with plywood for extra strength and anti-stash enclosed base. Ski foot designed to facilitate movement for use in multiples, if required, while also protecting flooring beneath. Gap left between base and floor to allow for easier cleaning and inspections. All cushioned areas are fixed to the base to ensure that they are not taken off and are made from fire retardant, CMHR (combustion modified high resilience) foam

TEST STANDARDS

- Fire retardant to BS 7176:2007 source 5
- Strength and stability tested to BS EN 15373:2007

OPTIONS

- Also available as a standard model
- Linking bracket to connect items

COLOUR/FINISH

Feet come in Natural as standard

FABRIC

Available in a wide choice of fabrics including Vinyl, Waterproof, Non Waterproof, Leather and Loose Cover

ASSEMBLY

Arrives assembled and ready to use

DELIVERY

INSTALLATION/FITTING

No fitting required

MAINTENANCE

See upholstered furniture section of our care guidelines for fabric care instructions

WARRANTY

7 year guarantee (does not include fabrics)

KEY FEATURES

- Plywood reinforcement, including a fully enclosed base to prevent concealment
- Versatile modular design helps you make the most of your space
- Ski feet protect flooring and facilitate movement
- Seat static weight tested to 200kg



MATERIAL/FABRICATION

Carcass made from a mix of particle board and plywood with wood veneer feet, fully reinforced with plywood for extra strength and anti-stash enclosed base. Ski foot designed to facilitate movement for use in multiples, if required, while also protecting flooring beneath. Gap left between base and floor to allow for easier cleaning and inspections. All cushioned areas are fixed to the base to ensure that they are not taken off and are made from fire retardant, CMHR (combustion modified high resilience) foam

TEST STANDARDS

- Fire retardant to BS 7176:2007 source 5
- Strength and stability tested to BS EN 15373:2007

OPTIONS

- Also available as a standard model
- Linking bracket to connect items

COLOUR/FINISH

Feet come in Natural as standard

FABRIC

Available in a wide choice of fabrics including Vinyl, Waterproof, Non Waterproof, Leather and Loose Cover

ASSEMBLY

Arrives assembled and ready to use

DELIVERY

INSTALLATION/FITTING

No fitting required

MAINTENANCE

See upholstered furniture section of our care guidelines for fabric care instructions

WARRANTY

7 year guarantee (does not include fabrics)

CONTESSA CUBE

1COFC-100

460H | 575W | 575D (mm)

Weight: 16.5kg



KEY FEATURES

- All foam construction with no internal frame for safety
- Zip heads removed and oversewn to prevent tampering
- Strong stitched seams
- CMHR foam provides a sturdy, fire-resistant core
- Static weight tested to 227kg



MATERIAL/FABRICATION

Over-sewn exterior available in a wide choice of fabrics. Removal of zip heads and over-sewn seams prevent tampering. Interior made from fire retardant, CMHR (combustion modified high resilience) foam to ensure maximum support, durability and comfort

TEST STANDARDS

- Fire retardant to BS 7176:2007 source 5
- Static weight tested to 227kg

OPTIONS

Also available in a variety of different shapes within the Contessa range

FABRIC

Available in a wide choice of fabrics including Vinyl, Waterproof, Non Waterproof and Leather (we recommend a dark coloured wipe-clean vinyl)

ASSEMBLY

Arrives assembled and ready to use

DELIVERY

INSTALLATION/FITTING

No fitting required

MAINTENANCE

See upholstered furniture section of our care guidelines

WARRANTY

7 year guarantee (does not include fabrics)

CONTESSA DRUM

1COFD-100

460 H | 575 Dia (mm)

Weight: 14.5kg



KEY FEATURES

- All foam construction with no internal frame for safety
- Zip heads removed and oversewn to prevent tampering
- Strong stitched seams
- CMHR foam provides a sturdy, fire-resistant core
- Static weight tested to 227kg



MATERIAL/FABRICATION

Over-sewn exterior available in a wide choice of fabrics. Removal of zip heads and over-sewn seams prevent tampering. Interior made from fire retardant, CMHR (combustion modified high resilience) foam to ensure maximum support, durability and comfort

TEST STANDARDS

- Fire retardant to BS 7176:2007 source 5
- Static weight tested to 227kg

OPTIONS

Also available in a variety of different shapes within the Contessa range

FABRIC

Available in a wide choice of fabrics including Vinyl, Waterproof, Non Waterproof and Leather (we recommend a dark coloured wipe-clean vinyl)

ASSEMBLY

Arrives assembled and ready to use

DELIVERY

INSTALLATION/FITTING

No fitting required

MAINTENANCE

See upholstered furniture section of our care guidelines

WARRANTY

7 year guarantee (does not include fabrics)



KEY FEATURES

- All foam construction with no internal frame for safety
- Zip heads removed and oversewn to prevent tampering
- Strong stitched seams
- CMHR foam provides a sturdy, fire-resistant core
- Static weight tested to 227kg



MATERIAL/FABRICATION

Over-sewn exterior available in a wide choice of fabrics. Removal of zip heads and over-sewn seams prevent tampering. Interior made from fire retardant, CMHR (combustion modified high resilience) foam to ensure maximum support, durability and comfort

TEST STANDARDS

- Fire retardant to BS 7176:2007 source 5
- Static weight tested to 227kg

OPTIONS

Also available in a variety of different shapes within the Contessa range

FABRIC

Available in a wide choice of fabrics including Vinyl, Waterproof, Non Waterproof and Leather (we recommend a dark coloured wipe-clean vinyl)

ASSEMBLY

Arrives assembled and ready to use

DELIVERY

INSTALLATION/FITTING

No fitting required

MAINTENANCE

See upholstered furniture section of our care guidelines

WARRANTY

7 year guarantee (does not include fabrics)



KEY FEATURES

- All foam construction with no internal frame for safety
- Zip heads removed and oversewn to prevent tampering
- Strong stitched seams
- CMHR foam provides a sturdy, fire-resistant core
- Static weight tested to 227kg



MATERIAL/FABRICATION

Over-sewn exterior available in a wide choice of fabrics. Removal of zip heads and over-sewn seams prevent tampering. Interior made from fire retardant, CMHR (combustion modified high resilience) foam to ensure maximum support, durability and comfort

TEST STANDARDS

- Fire retardant to BS 7176:2007 source 5
- Static weight tested to 227kg

OPTIONS

Also available in a variety of different shapes within the Contessa range

FABRIC

Available in a wide choice of fabrics including Vinyl, Waterproof, Non Waterproof and Leather (we recommend a dark coloured wipe-clean vinyl)

ASSEMBLY

Arrives assembled and ready to use

DELIVERY

INSTALLATION/FITTING

No fitting required

MAINTENANCE

See upholstered furniture section of our care guidelines

WARRANTY

7 year guarantee (does not include fabrics)

CONTESSA CUBOID

1COFCUB-100

460H | 1150W | 575D (mm)

Weight: 33kg



KEY FEATURES

- All foam construction with no internal frame for safety
- Zip heads removed and oversewn to prevent tampering
- Strong stitched seams
- CMHR foam provides a sturdy, fire-resistant core
- Static weight tested to 227kg



MATERIAL/FABRICATION

Over-sewn exterior available in a wide choice of fabrics. Removal of zip heads and over-sewn seams prevent tampering. Interior made from fire retardant, CMHR (combustion modified high resilience) foam to ensure maximum support, durability and comfort

TEST STANDARDS

- Fire retardant to BS 7176:2007 source 5
- Static weight tested to 227kg

OPTIONS

Also available in a variety of different shapes within the Contessa range

FABRIC

Available in a wide choice of fabrics including Vinyl, Waterproof, Non Waterproof and Leather (we recommend a dark coloured wipe-clean vinyl)

ASSEMBLY

Arrives assembled and ready to use

DELIVERY

INSTALLATION/FITTING

No fitting required

MAINTENANCE

See upholstered furniture section of our care guidelines

WARRANTY

7 year guarantee (does not include fabrics)



KEY FEATURES

- All foam construction with no internal frame for safety
- Zip heads removed and oversewn to prevent tampering
- Strong stitched seams
- CMHR foam provides a sturdy, fire-resistant core
- Static weight tested to 227kg



MATERIAL/FABRICATION

Over-sewn exterior available in a wide choice of fabrics. Removal of zip heads and over-sewn seams prevent tampering. Interior made from fire retardant, CMHR (combustion modified high resilience) foam to ensure maximum support, durability and comfort

TEST STANDARDS

- Fire retardant to BS 7176:2007 source 5
- Static weight tested to 227kg

OPTIONS

Also available in a variety of different shapes within the Contessa range

FABRIC

Available in a wide choice of fabrics including Vinyl, Waterproof, Non Waterproof and Leather (we recommend a dark coloured wipe-clean vinyl)

ASSEMBLY

Arrives assembled and ready to use

DELIVERY

INSTALLATION/FITTING

No fitting required

MAINTENANCE

See upholstered furniture section of our care guidelines

WARRANTY

7 year guarantee (does not include fabrics)



KEY FEATURES

- All foam construction with no internal frame for safety
- Zip heads removed and oversewn to prevent tampering
- Strong stitched seams
- CMHR foam provides a sturdy, fire-resistant core
- Static weight tested to 227kg



MATERIAL/FABRICATION

Over-sewn exterior available in a wide choice of fabrics. Removal of zip heads and over-sewn seams prevent tampering. Interior made from fire retardant, CMHR (combustion modified high resilience) foam to ensure maximum support, durability and comfort

TEST STANDARDS

- Fire retardant to BS 7176:2007 source 5
- Static weight tested to 227kg

OPTIONS

Also available in a variety of different shapes within the Contessa range

FABRIC

Available in a wide choice of fabrics including Vinyl, Waterproof, Non Waterproof and Leather (we recommend a dark coloured wipe-clean vinyl)

ASSEMBLY

Arrives assembled and ready to use

DELIVERY

INSTALLATION/FITTING

No fitting required

MAINTENANCE

See upholstered furniture section of our care guidelines

WARRANTY

7 year guarantee (does not include fabrics)

KEY FEATURES



- All foam construction for safety
- Strong stitched seams (please note, fluid can penetrate stitching)
- Zip heads removed and oversewn to prevent tampering
- CMHR foam construction is safe for both users and staff

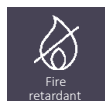

MATERIAL/FABRICATION

Fully stitched cover available in a wide choice of fabrics. For further durability, the cover for the Cascade Plus range made from anti-vandal, polyurethane coated nylon. This anti-microbial, wipe clean exterior offers excellent hygiene properties. Optional wedge design at the front aids de-escalation for a more peaceful environment. Interior made from fire retardant, CMHR (combustion modified high resiliency) foam so is safe for both users and staff

TEST STANDARDS

- Fire retardant to BS 7176:2007 source 5
- Tear strength tested to Warp BS 3424:4982: min 50 N) Weft Part 5: Method 7B min 50 standard

OPTIONS

- Low back chair options with/without the wedge is available
- Cascade Plus range with anti-vandal, water-resistant material is also available for challenging environments

COLOUR/FINISH

Available in a wide choice of fabrics including Vinyl, Waterproof, Non Waterproof and Leather

ASSEMBLY

Arrives assembled and ready to use

DELIVERY

INSTALLATION/FITTING

No fitting required

MAINTENANCE

See upholstered furniture section of our care guidelines for fabric care instructions

WARRANTY

7 year guarantee (does not include fabrics)

CASCADE PLUS LOW BACK CHAIR

1CSCL-100

930H | 600W | 920D (mm)

Seat Height: 430mm



KEY FEATURES

- All foam construction for safety
- Zip heads removed and oversewn to prevent tampering
- Optional wedge at the front of the calm chair to aid de-escalation
- CMHR foam construction is safe for both users and staff
- Anti-vandal, water-resistant material offers excellent hygiene properties

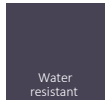

MATERIAL/FABRICATION

The cover for the Cascade Plus range made from anti-vandal, polyurethane coated nylon. This anti-microbial, wipe clean exterior offers excellent hygiene properties. Optional wedge design at the front aids de-escalation for a more peaceful environment. Interior made from fire retardant, CMHR (combustion modified high resilience) foam so is safe for both users and staff

TEST STANDARDS

- Fire retardant to BS 7176:2007 source 5
- Tear strength tested to Warp BS 3424:4982: min 50 N) Weft Part 5: Method 7B min 50 standard

OPTIONS

- Low back option with/without the wedge is also available
- High back options are also available in Cascade Plus
- Standard Cascade range, without anti-vandal, water-resistant material is also available for lower risk areas

COLOUR/FINISH

Blue, Violet, Orange, Green

ASSEMBLY

Arrives assembled and ready to use

DELIVERY

INSTALLATION/FITTING

No fitting required

MAINTENANCE

See upholstered furniture section of our care guidelines for fabric care instructions

WARRANTY

7 year guarantee (does not include fabrics)

CASCADE PLUS HIGH BACK CHAIR

1CSH-100

1200H | 600W | 920D (mm)

Seat Height: 430mm



KEY FEATURES

- All foam construction for safety
- Zip heads removed and oversewn to prevent tampering
- Optional wedge at the front of the calm chair to aid de-escalation
- CMHR foam construction is safe for both users and staff
- Anti-vandal, water-resistant material offers excellent hygiene properties

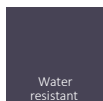

MATERIAL/FABRICATION

The cover for the Cascade Plus range made from anti-vandal, polyurethane coated nylon. This anti-microbial, wipe clean exterior offers excellent hygiene properties. Optional wedge design at the front aids de-escalation for a more peaceful environment. Interior made from fire retardant, CMHR (combustion modified high resilience) foam so is safe for both users and staff

TEST STANDARDS

- Fire retardant to BS 7176:2007 source 5
- Tear strength tested to Warp BS 3424:4982: min 50 N) Weft Part 5: Method 7B min 50 standard

OPTIONS

- High back option with/without the wedge is also available
- Low back options are also available in Cascade Plus
- Standard Cascade range, without anti-vandal, water-resistant material is also available for lower risk areas

COLOUR/FINISH

Blue, Violet, Orange, Green

ASSEMBLY

Arrives assembled and ready to use

DELIVERY

INSTALLATION/FITTING

No fitting required

MAINTENANCE

See upholstered furniture section of our care guidelines for fabric care instructions

WARRANTY

7 year guarantee (does not include fabrics)



KEY FEATURES

- All foam construction for safety
- Strong stitched seams (please note, fluid can penetrate stitching)
- Zip heads removed and oversewn to prevent tampering
- CMHR foam construction is safe for both users and staff
- Wedge at front aid de-escalation



MATERIAL/FABRICATION

Fully stitched cover available in a wide choice of fabrics. The cover for the Cascade Plus range made from anti-vandal, polyurethane coated nylon. This anti-microbial, wipe clean exterior offers excellent hygiene properties. Optional wedge design at the front aids de-escalation for a more peaceful environment. Interior made from fire retardant, CMHR (combustion modified high resillience) foam so is safe for both users and staff

TEST STANDARDS

- Fire retardant to BS 7176:2007 source 5
- Tear strength tested to Warp BS 3424:4982: min 50 N) Weft Part 5: Method 7B min 50 standard

OPTIONS

- Low back chair options with/without the wedge is also available
- Cascade Plus range with anti-vandal, water-resistant material is also available for challenging environments

COLOUR/FINISH

Available in a wide choice of fabrics including Vinyl, Waterproof, Non Waterproof and Leather

ASSEMBLY

Arrives assembled and ready to use

DELIVERY

INSTALLATION/FITTING

No fitting required

MAINTENANCE

See upholstered furniture section of our care guidelines for fabric care instructions

WARRANTY

7 year guarantee (does not include fabrics)

CASCADE PLUS LOW BACK CALM CHAIR

1CSCL-100

930H | 670W | 1050D (mm)

Seat Height: 430mm



KEY FEATURES

- All foam construction for safety
- Zip heads removed and oversewn to prevent tampering
- Optional wedge at the front of the calm chair to aid de-escalation
- CMHR foam construction is safe for both users and staff
- Anti-vandal, water-resistant material offers excellent hygiene properties



MATERIAL/FABRICATION

The cover for the Cascade Plus range made from anti-vandal, polyurethane coated nylon. This anti-microbial, wipe clean exterior offers excellent hygiene properties. Optional wedge design at the front aids de-escalation for a more peaceful environment. Interior made from fire retardant, CMHR (combustion modified high resilience) foam so is safe for both users and staff

TEST STANDARDS

- Fire retardant to BS 7176:2007 source 5
- Tear strength tested to Warp BS 3424:4982: min 50 N) Weft Part 5: Method 7B min 50 standard

OPTIONS

- Low back option with/without the wedge is also available
- High back options are also available in Cascade Plus
- Standard Cascade range, without anti-vandal, water-resistant material is also available for lower risk areas

COLOUR/FINISH

Blue, Violet, Orange, Green

ASSEMBLY

Arrives assembled and ready to use

DELIVERY

INSTALLATION/FITTING

No fitting required

MAINTENANCE

See upholstered furniture section of our care guidelines for fabric care instructions

WARRANTY

7 year guarantee (does not include fabrics)

CASCADE PLUS HIGH BACK CALM CHAIR

1CSM-100

1200H | 670W | 1100D (mm)

Seat Height: 430mm



KEY FEATURES

- All foam construction for safety
- Zip heads removed and oversewn to prevent tampering
- Optional wedge at the front of the calm chair to aid de-escalation
- CMHR foam construction is safe for both users and staff
- Anti-vandal, water-resistant material offers excellent hygiene properties



MATERIAL/FABRICATION

The cover for the Cascade Plus range made from anti-vandal, polyurethane coated nylon. This anti-microbial, wipe clean exterior offers excellent hygiene properties. Optional wedge design at the front aids de-escalation for a more peaceful environment. Interior made from fire retardant, CMHR (combustion modified high resilience) foam so is safe for both users and staff

TEST STANDARDS

- Fire retardant to BS 7176:2007 source 5
- Tear strength tested to Warp BS 3424:4982: min 50 N) Weft Part 5: Method 7B min 50 standard

OPTIONS

- High back option with/without the wedge is also available
- Low back options are also available in Cascade Plus
- Standard Cascade range, without anti-vandal, water-resistant material is also available for lower risk areas

COLOUR/FINISH

Blue, Violet, Orange, Green

ASSEMBLY

Arrives assembled and ready to use

DELIVERY

INSTALLATION/FITTING

No fitting required

MAINTENANCE

See upholstered furniture section of our care guidelines for fabric care instructions

WARRANTY

7 year guarantee (does not include fabrics)

CASCADE PLUS HIGH BACK CALM BENCH

1CSCBH-100

1200H | 1800W | 1095D (mm)

Seat Height: 430mm

KEY FEATURES

- All foam construction for safety
- Zip heads removed and oversewn to prevent tampering
- CMHR foam construction is safe for both users and staff
- Anti-vandal, water-resistant material offers excellent hygiene properties

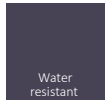

MATERIAL/FABRICATION

The cover for the Cascade Plus range made from anti-vandal, polyurethane coated nylon. This anti-microbial, wipe clean exterior offers excellent hygiene properties. Optional wedge design at the front aids de-escalation for a more peaceful environment. Interior made from fire retardant, CMHR (combustion modified high resilience) foam so is safe for both users and staff

TEST STANDARDS

- Fire retardant to BS 7176:2007 source 5
- Tear strength tested to Warp BS 3424:4982: min 50 N) Weft Part 5: Method 7B min 50 standard

OPTIONS

- High back chair options with/without the wedge is also available
- Low back options are also available in Cascade Plus
- Standard Cascade range, without anti-vandal, water-resistant material is also available for lower risk areas

COLOUR/FINISH

Blue, Violet, Orange, Green

ASSEMBLY

Arrives assembled and ready to use

DELIVERY

INSTALLATION/FITTING

No fitting required

MAINTENANCE

See upholstered furniture section of our care guidelines for fabric care instructions

WARRANTY

7 year guarantee (does not include fabrics)

BODEN BEAN BAG

1B01-400

800H | 900W | 900D (mm)

Weight: 7kg



KEY FEATURES

- Double stitched seams and non-accessible zips prevent tampering
- Flame retardant filling gives the beanbags their shape and comfort
- Internal seam lining provides an extra layer of protection
- Static weight tested to 227kg



MATERIAL/FABRICATION

Fully stitched, polystyrene filled bean bag available in a wide choice of fabrics. Designed to have non-accessible zips to prevent tampering

TEST STANDARDS

- Fire retardant to BS 7176:2007 source 5
- Static weight tested to 227kg

FABRICS

A wide choice of fabrics including water-resistant and leather. For non-carpeted areas, we strongly recommend a wipeable vinyl

ASSEMBLY

Arrives assembled and ready to use

DELIVERY

INSTALLATION/FITTING

No fitting required

MAINTENANCE

See upholstered furniture section of our care guidelines

WARRANTY

2 year guarantee (does not include fabrics)



KEY FEATURES

- Double stitched seams and non-accessible zips prevent tampering
- Flame retardant filling gives the beanbags their shape and comfort
- Internal seam lining provides an extra layer of protection
- Static weight tested to 227kg



MATERIAL/FABRICATION

Fully stitched, polystyrene filled bean bag available in a wide choice of fabrics. Designed to have non-accessible zips to prevent tampering

TEST STANDARDS

- Fire retardant to BS 7176:2007 source 5
- Static weight tested to 227kg

FABRICS

A wide choice of fabrics including water-resistant and leather. For non-carpeted areas, we strongly recommend a wipeable vinyl

ASSEMBLY

Arrives assembled and ready to use

DELIVERY

INSTALLATION/FITTING

No fitting required

MAINTENANCE

See upholstered furniture section of our care guidelines

WARRANTY

2 year guarantee (does not include fabrics)



KEY FEATURES

- Double stitched seams and non-accessible zips prevent tampering
- Flame retardant filling gives the beanbags their shape and comfort
- Internal seam lining provides an extra layer of protection
- Static weight tested to 227kg



MATERIAL/FABRICATION

Fully stitched, polystyrene filled bean bag available in a wide choice of fabrics. Designed to have non-accessible zips to prevent tampering

TEST STANDARDS

- Fire retardant to BS 7176:2007 source 5
- Static weight tested to 227kg

FABRICS

A wide choice of fabrics including water-resistant and leather. For non-carpeted areas, we strongly recommend a wipeable vinyl

ASSEMBLY

Arrives assembled and ready to use

DELIVERY

INSTALLATION/FITTING

No fitting required

MAINTENANCE

See upholstered furniture section of our care guidelines

WARRANTY

2 year guarantee (does not include fabrics)



KEY FEATURES

- Armless design assists de-escalation practices and reduces likelihood of damage
- Fully plywood reinforcement for extra strength and weight
- Seat static weight tested to 200kg



MATERIAL/FABRICATION

Constructed from a solid timber frame with plywood reinforcement for strength and durability. The Reef has been designed with a reduced arm to assist staff with safe de-escalation practises. Additional reinforcement levels are available, making it perfect for demanding environments. Cushioned areas made from fire retardant, CMHR (combustion modified high resilience) foam is safe for both users and staff

TEST STANDARDS

- Fire retardant to BS7176:2007 source 5
- Strength and stability tested to BS EN 15373:2007
- Seat static weight tested to 200kg

OPTIONS

- Wide choice of water-resistant upholstery

COLOUR/FINISH

Feet available in Natural or Walnut

FABRIC

Available in a wide choice of fabrics including Vinyl, Waterproof, Non Waterproof and Leather

ASSEMBLY

Arrives assembled and ready to use

DELIVERY

INSTALLATION/FITTING

No fitting required

MAINTENANCE

See upholstered furniture section of our care guidelines

WARRANTY

7 year guarantee (does not include fabrics)

KEY FEATURES



- Standard reinforcement provides strength and durability
- Versatile modular design helps you make the most of your space
- Can be used individually or in multiples
- Plinth base to prevent dust and dirt gathering underneath
- Static load tested up to 110kg



MATERIAL/FABRICATION

Doorne is a modular seating solution that is constructed from plywood and softwood with a solid Birch plinth base. Doorne offers a flexible seating solution that can be configured to suit any small or larger space. Furniture glides on the plinth base allows for ease of movement, and ensures the floor is protected from potential damage.

TEST STANDARDS

- Strength and stability (EN 16139:2013 Test Level 2)
- Static load tested up to 110kg
- All upholstery flammability rated to Crib 5 or Crib 7

OPTIONS

- Available in standard or Doorne Plus
- Also available in a double and curved modular seating standard option (as below)

Doorne double
1DRM2-100
450H | 900W | 450D (mm)
Weight: 16kg



Doorne 45° curved
1DRM3-100
450H | 730W | 450D (mm)
Weight: 11.5kg



COLOUR/FINISH

Lacquered solid Birch plinth

FABRIC

Available in a wide choice of hard wearing, water-resistant fabrics and leather effect vinyl upholstery options.

ASSEMBLY

Arrives assembled and ready to use

INSTALLATION/FITTING

No fitting required

MAINTENANCE

See upholstered furniture section of our care guidelines for fabric care instructions

WARRANTY

7 year guarantee (does not include fabric/vinyl)

KEY FEATURES



- Plus reinforcement provides additional weight for strength and durability
- Versatile modular design helps you make the most of your space
- Can be used individually or in multiples
- Plinth base to prevent dust and dirt gathering underneath
- Static load tested up to 110kg



MATERIAL/FABRICATION

Doorne is a modular seating solution that is constructed from plywood and softwood with a solid Birch plinth base. Doorne offers a flexible seating solution that can be configured to suit any small or larger space. Furniture glides on the plinth base allows for ease of movement, and ensures the floor is protected from potential damage. Doorne Plus includes additional weight and safety features in the range.

TEST STANDARDS

- Strength and stability (EN 16139:2013 Test Level 2)
- Static load tested up to 110kg
- All upholstery flammability rated to Crib 5 or Crib 7

OPTIONS

- Available in standard or Doorne Plus
- Also available in a double and curved modular seating standard option (as below)

Doorne Plus double
1DRMP2-400
450H | 900W | 450D (mm)
Weight: 45kg



Doorne Plus 45° curved
1DRMP3-400
450H | 730W | 450D (mm)
Weight: 26kg



COLOUR/FINISH

Lacquered solid Birch plinth

FABRIC

Available in a wide choice of hard wearing, water-resistant fabrics and leather effect vinyl upholstery options.

ASSEMBLY

Arrives assembled and ready to use

INSTALLATION/FITTING

No fitting required

MAINTENANCE

See upholstered furniture section of our care guidelines for fabric care instructions

WARRANTY

7 year guarantee (does not include fabric/vinyl)

CODA ARMCHAIR

1CDA1-900

815H | 945W | 800D (mm)

Seat Height: 450mm

Weight: 40kg



KEY FEATURES

- 40mm space between cushions to prevent concealment and make inspection safer
- Unlike conventional sofas, there are no dirt-traps and can be thoroughly cleaned
- Powdercoated steel frame and feet which are resistant to moisture from cleaning
- Plywood reinforcement for strength
- Seat static weight tested to 500kg



MATERIAL/FABRICATION

Coda is a fully plywood reinforced, anti-stash seating range with a 40mm space between the seat platform and the arms and back, making visual inspections easier and preventing concealment opportunities. Coda is raised off the ground to improve visibility and further aid cleaning practises. A matt black powdercoated metal frame with security fixings includes black plastic feet glides to prevent floor damage

TEST STANDARDS

- Strength & stability (EN 16139:2013 Level 2)
- Extra durability (500,000 seat and back cycles)
- Static weight test (seat) 500kg

OPTIONS

- Available in 2-tone upholstered finish
- Also available in a 2 & 3-Seater option (as below)

2-Seater
1CDA2-900
815H | 1545W | 800D (mm)
Seat Height: 450mm
Weight: 50kg



3-Seater
1CDA3-900
815H | 2000W | 800D (mm)
Seat Height: 450mm
Weight: 90kg



COLOUR/FINISH

Available in a wide range of upholstery options with a black mild steel powdercoated metal (RAL 9005) underframe

DELIVERY

ASSEMBLY

Arrives assembled and ready to use

INSTALLATION/FITTING

No fitting required

MAINTENANCE

See upholstered furniture section of our care guidelines

WARRANTY

7 year guarantee

CODA ARMCHAIR

1CDA1-900

815H | 945W | 800D (mm)

Seat Height: 450mm

Weight: 40kg

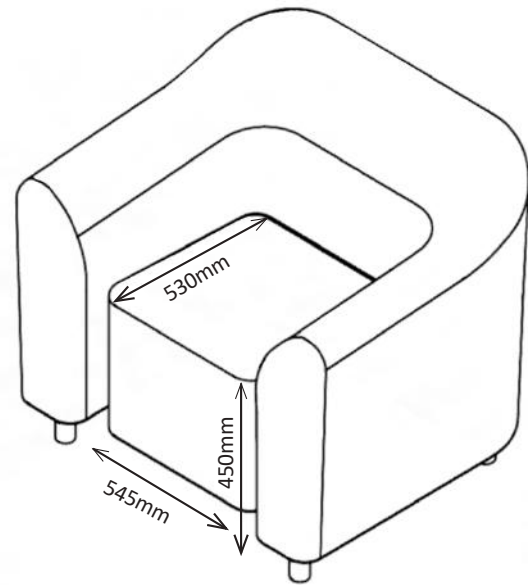
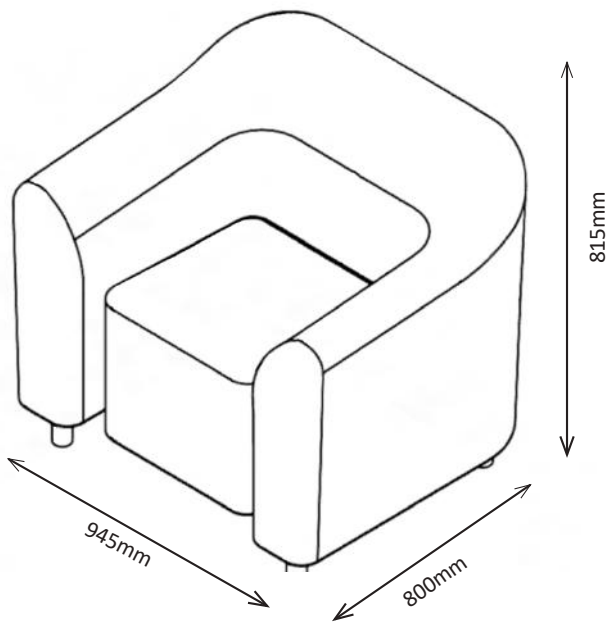

072 836 6193 / 021 201 7199

enquiries@apex-ergo.co.za

www.apex-ergo.co.za



CODA 2-SEATER

1CDA2-900

815H | 1545W | 800D (mm)

Seat Height: 450mm

Weight: 50kg



KEY FEATURES

- 40mm space between cushions to prevent concealment and make inspection safer
- Unlike conventional sofas, there are no dirt-traps and can be thoroughly cleaned
- Powdercoated steel frame and feet which are resistant to moisture from cleaning
- Plywood reinforcement for strength
- Seat static weight tested to 500kg



MATERIAL/FABRICATION

Coda is a fully plywood reinforced, anti-stash seating range with a 40mm space between the seat platform and the arms and back, making visual inspections easier and preventing concealment opportunities. Coda is raised off the ground to improve visibility and further aid cleaning practises. A matt black powdercoated metal frame with security fixings includes black plastic feet glides to prevent floor damage

TEST STANDARDS

- Strength & stability (EN 16139:2013 Level 2)
- Extra durability (500,000 seat and back cycles)
- Static weight test (seat) 500kg

OPTIONS

- Available in 2-tone upholstered finish
- Armchair & 3-Seater option available (as below)

Armchair
1CDA1-900
815H | 945W | 800D (mm)
Seat Height: 450mm
Weight: 40kg



3-Seater
1CDA3-900
815H | 2000W | 800D (mm)
Seat Height: 450mm
Weight: 90kg



COLOUR/FINISH

Available in a wide range of upholstery options with a black mild steel powdercoated metal (RAL 9005) underframe

DELIVERY

ASSEMBLY

Arrives assembled and ready to use

INSTALLATION/FITTING

No fitting required

MAINTENANCE

See upholstered furniture section of our care guidelines

WARRANTY

7 year guarantee

CODA 2-SEATER

1CDA2-900

815H | 1545W | 800D (mm)

Seat Height: 450mm

Weight: 50kg

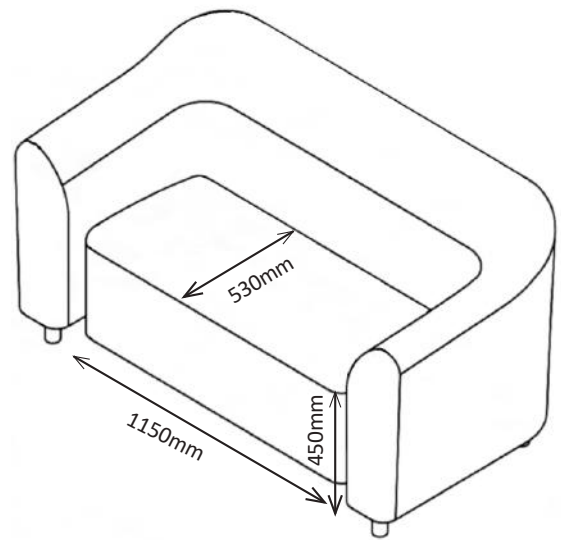
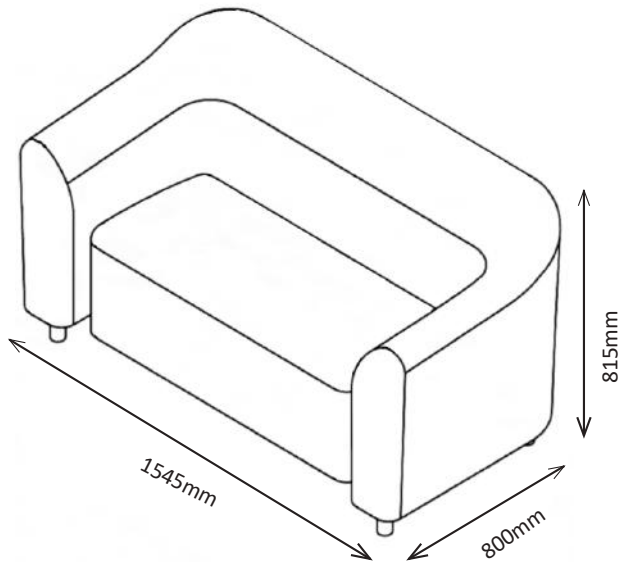

072 836 6193 / 021 201 7199

enquiries@apex-ergo.co.za

www.apex-ergo.co.za



CODA 3-SEATER

1CDA3-900

815H | 2000W | 800D (mm)

Seat Height: 450mm

Weight: 90kg



KEY FEATURES

- 40mm space between cushions to prevent concealment and make inspection safer
- Unlike conventional sofas, there are no dirt-traps and can be thoroughly cleaned
- Powdercoated steel frame and feet which are resistant to moisture from cleaning
- Plywood reinforcement for strength
- Seat static weight tested to 500kg



MATERIAL/FABRICATION

Coda is a fully plywood reinforced, anti-stash seating range with a 40mm space between the seat platform and the arms and back, making visual inspections easier and preventing concealment opportunities. Coda is raised off the ground to improve visibility and further aid cleaning practises. A matt black powdercoated metal frame with security fixings includes black plastic feet glides to prevent floor damage

TEST STANDARDS

- Strength & stability (EN 16139:2013 Level 2)
- Extra durability (500,000 seat and back cycles)
- Static weight test (seat) 500kg

OPTIONS

- Available in 2-tone upholstered finish
- Armchair & 2-Seater option available (as below)

Armchair
1CDA1-900
815H | 945W | 800D (mm)
Seat Height: 450mm
Weight: 40kg



2-Seater
1CDA2-900
815H | 1545W | 800D (mm)
Seat Height: 450mm
Weight: 50kg



COLOUR/FINISH

Available in a wide range of upholstery options with a black mild steel powdercoated metal (RAL 9005) underframe

DELIVERY

ASSEMBLY

Arrives assembled and ready to use

INSTALLATION/FITTING

No fitting required

MAINTENANCE

See upholstered furniture section of our care guidelines

WARRANTY

7 year guarantee

CODA 3-SEATER

1CDA3-900

815H | 2000W | 800D (mm)

Seat Height: 450mm

Weight: 90kg

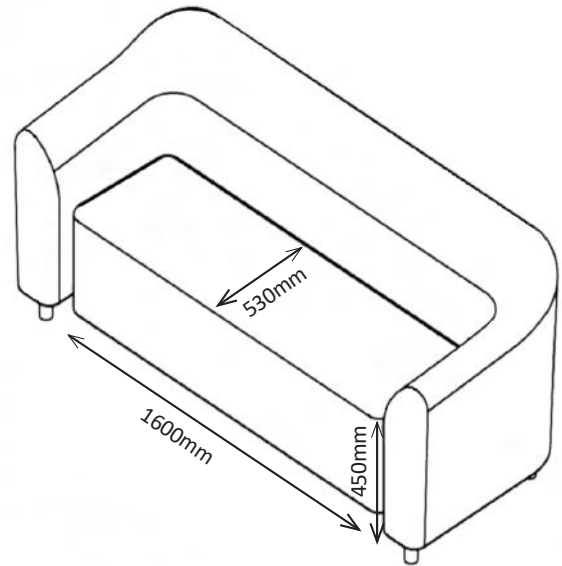
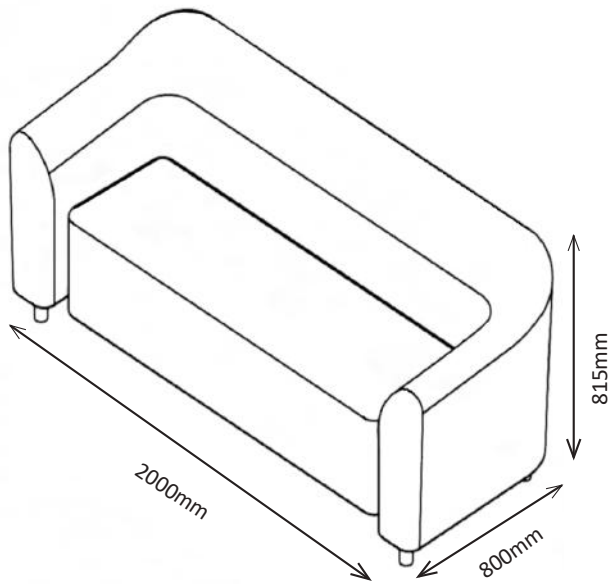

GANT EXTRA FAST FOOD UNIT

1GE4-500

860H | 2300W | 2300D (mm)

Table Top: ø 1220Dia (mm)

Table Height: 860mm

Seat Height: 455mm



KEY FEATURES

- Natural wood effect laminate top - heat and impact resistant
- Padded seats for comfort
- Inaccessible staples and security screws as standard
- Integral floor mounting brackets for additional security



MATERIAL/FABRICATION

Designed in a larger size than the Gant Fast Food Unit. Constructed using a strong, fully welded metal frame with additional floor mounting brackets for added security. The chairs have padded seats that provide comfort and strength and are available in a range of colours. Interior made from fire retardant, CMHR (combustion modified high resilience) foam so is safe for both users and staff

TEST STANDARDS

- All fabrics fire retardant to BS 7176:2007 source 5
- Strength and stability tested to BS EN 15373:2007

OPTIONS

- Also available in a smaller size (see Gant Fast Food Unit)

FABRIC

Available in a wide choice of fabrics including Vinyl, Waterproof, Non Waterproof and Leather

COLOUR/FINISH

Table top available in Natural Wood effect.

DELIVERY

ASSEMBLY

Arrives assembled and ready to use

INSTALLATION/FITTING

No fitting required

MAINTENANCE

See upholstered furniture section of our care guidelines

WARRANTY

7 year guarantee (does not include fabrics)



KEY FEATURES

- Natural wood effect laminate top - heat and impact resistant
- Padded seats in metal frame provide comfort and strength
- Fully welded frame with stylish silver finish
- Floor mounting brackets for added security
- Inaccessible staples and security screws as standard



MATERIAL/FABRICATION

Constructed using a strong, fully welded metal frame with additional floor mounting brackets for added security. The chairs have padded seats that provide comfort and strength and are available in a range of colours. Interior made from fire retardant, CMHR (combustion modified high resilience) foam so is safe for both users and staff

TEST STANDARDS

- All fabrics fire retardant to BS 7176:2007 source 5
- Strength and stability tested to BS EN 15373:2007

OPTIONS

- Also available with a chequerboard top (as below)

1GA4-400
860H | 1480 W | 1480 D (mm)
Table Top: ø 900Dia (mm)
Seat Height: 455mm



FABRIC

Available in a wide choice of fabrics including Vinyl, Waterproof, Non Waterproof and Leather

COLOUR/FINISH

Table top available in Natural Wood effect.

DELIVERY

ASSEMBLY

Arrives assembled and ready to use

INSTALLATION/FITTING

No fitting required

MAINTENANCE

See upholstered furniture section of our care guidelines

WARRANTY

7 year guarantee (does not include fabrics)

ROCK CHAIR

1RK1-BIR-WHITE

810H | 520W | 520D (mm)

Seat height: 460mm

Weight: 7.5kg



UK Registered Design No. 6131310

KEY FEATURES

- Cross-braced skis provide additional strength and manoeuvrability
- One-piece seat with wipe-clean laminate surface
- Strong and durable solid Birch frame
- Seat static weight tested to 317kg



MATERIAL/FABRICATION

Lacquered solid Birch frame with plywood seat in Egger Platinum White ST15 laminate finish. Key to the range's strength (tested for severe contract use; BS EN 16139:2013 level 2) are the interconnections which join each leg together, creating a rigid solid Birch frame which maximises durability and minimises damage. Seat and back is constructed from 10mm thick wood, the legs are 36mm x 45mm with a 25mm sled base. The arms attached is constructed from a powdercoated curved mild steel tube.

TEST STANDARDS

- Strength and stability tested for severe contract use (BS EN 16139:2013 level 2)
- Exceeded the 200,000 cycle pass mark by a further 300,000 cycles
- EN1728:2012 6.4 seat and back tested to 317kg / 50 stone weight

OPTIONS

- Matching coffee and dining tables available
- Rock chair with arms also available

1RK1-300-BIRWHT
810H | 560W | 550D (mm)



COLOUR/FINISH

Seat platform is in Egger Platinum White ST15 laminate finish. Frame comes in Birch as standard

ASSEMBLY

Arrives assembled and ready to use

INSTALLATION/FITTING

No fitting required

MAINTENANCE

Easy to keep clean with a soft damp cloth and use of a non-abrasive cream cleaner is acceptable. Do not use solvents, bleaches, abrasives or synthetic detergents. Avoid getting product wet. If this occurs dry thoroughly. Table tops are heat resistant but not heat proof so avoid putting items straight from the oven directly in contact with the top

WARRANTY

5 year guarantee

FUSION CHAIR

1FU1-400A

900H | 440W | 700D (mm)

Seat Height: 490mm

Weight: 45kg



KEY FEATURES

- Heavily weighted to 45kg to increase stability and deter misuse
- Fully upholstered with stitched seams and security fixings (no piping or staples)
- Solid Beech skis for manoeuvrability
- Solid 18mm thick plywood seat and base panels



MATERIAL/FABRICATION

Carcass is made from solid 45 x 45mm timber framework, with 18mm thick plywood seat and base panels for support and reinforcement. Plywood base panels allows staples to be hidden to deter misuse. Interior made from fire retardant, CMHR (combustion modified high resilience) foam so is safe for both users and staff

TEST STANDARDS

- All fabrics fire retardant to BS 7176:2007 source 5
- BS EN 1021-1:2006
- BS 5852:2006

OPTIONS

- Wide choice of water-resistant upholstery

COLOUR/FINISH

Skis available in solid Beech

DELIVERY

ASSEMBLY

Arrives assembled and ready to use

INSTALLATION/FITTING

No fitting required

MAINTENANCE

See upholstered furniture section of our care guidelines

WARRANTY

7 year guarantee (does not include fabrics)

T

072 836 6193 / 021 201 7199

E

enquiries@apex-ergo.co.za

W

www.apex-ergo.co.za



NERO CHAIR

1N01-200

820H | 570W | 460D (mm)

Seat Height: 430mm

Weight: 4kg



KEY FEATURES

- Multi-purpose stacking chair
- One-piece seat with hygienic wipe-clean surface
- UV stabilised water resistant material is suitable for indoor and outdoor use
- Polypropylene reinforced with glass fibre construction



Fire
retardant

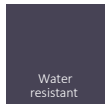

Water
resistant



MATERIAL/FABRICATION

Lightweight yet durable polypropylene injection-moulded structure with glass fibre reinforcement. Its water-resistant shell makes it suitable for indoor and outdoor use as well as making it easy to clean. Designed to stack on top of each other for practical storage.

TEST STANDARDS

- Strength and stability tested to BS EN 15373:2007

COLOUR/FINISH

Available in Orange, Blue, Black, Red and Green

ASSEMBLY

Arrives assembled and ready to use

DELIVERY

INSTALLATION/FITTING

No fitting required

MAINTENANCE

Wipe-clean surface is easy to keep sanitised with a soft cloth. Use of multipurpose cleaning wipes, gentle general household detergents, degreasers or anti-bacterial cleaners is recommended. Avoid using abrasive materials or cleaning agents, solvents, steam cleaning or jet washing. Use bleach and chlorine disinfectant with caution and avoid placing in close proximity to sources of heat.

WARRANTY

7 year guarantee

T

072 836 6193 / 021 201 7199

E

enquiries@apex-ergo.co.za

W

www.apex-ergo.co.za





KEY FEATURES

- Strong one-piece wrap around arm
- Braced legs for additional stability
- Corner braces under seat provides additional strength
- Solid Beech construction
- Seat static weight tested to 160kg



MATERIAL/FABRICATION

Wooden construction designed with braced legs for additional stability. Corner braces under seat also provide extra strength

TEST STANDARDS

- Strength and stability tested to BS EN 15373:2007
- Fire retardant to BS 7176:2007 source 5

OPTIONS

- Minimum order quantity x 4 chairs
- Skis available to protect flooring and facilitate movement
- Available with polished wood or padded back and/or upholstered seat (seat height becomes 480mm when upholstered)

1NS1-200
875H | 530W | 540D (mm)
Seat Height: 480mm



1NS1-400
875H | 530W | 540D (mm)
Seat Height: 480mm



COLOUR/FINISH

Frame available in Natural

FABRIC

Available in a wide choice of fabrics including Vinyl, Waterproof, Non Waterproof and Leather

DELIVERY

ASSEMBLY

Arrives assembled and ready to use

INSTALLATION/FITTING

No fitting required

MAINTENANCE

See upholstered furniture section of our care guidelines

WARRANTY

7 year guarantee (does not include fabrics)



KEY FEATURES

- Braced legs for additional stability
- Corner braces under seat provides additional strength
- Solid Beech construction
- Seat static weight tested to 160kg



MATERIAL/FABRICATION

Wooden construction designed with braced legs for additional stability. Corner braces under seat also provide extra strength

TEST STANDARDS

- Strength and stability tested to BS EN 15373:2007
- Fire retardant to BS 7176:2007 source 5

OPTIONS

- Minimum order quantity x 4 chairs
- Skis available to protect flooring and facilitate movement
- Available with polished wood or padded back and/or upholstered seat (seat height becomes 480mm when upholstered)

1NS1-100
875H | 480W | 540D (mm)
Seat Height: 480mm



1NS1-300
875H | 480W | 540D (mm)
Seat Height: 480mm



COLOUR/FINISH

Frame available in Natural

FABRIC

Available in a wide choice of fabrics including Vinyl, Waterproof, Non Waterproof and Leather

DELIVERY

ASSEMBLY

Arrives assembled and ready to use

INSTALLATION/FITTING

No fitting required

MAINTENANCE

See upholstered furniture section of our care guidelines

WARRANTY

7 year guarantee (does not include fabrics)

CADREGA DINING CHAIR WITH ARMS

1CGD1-400

800H | 600W | 550D (mm)

Seat Height: 440mm

Weight: 9kg



KEY FEATURES

- Stackable dining chairs (4 high) with a minimalist design ethos
- Hygiene-gap between seat and back to prevent dirt and dust gathering
- Seat static weight tested to 227kg
- Solid birch legs and frame



MATERIAL/FABRICATION

Elegantly styled and compact in size, stackable for easy storage when not in use (4 high). Cushioned areas made from fire retardant, high density CMHR (combustion modified high resilience) foam is safe for both users and staff.

TEST STANDARDS

- Fire retardant to BS7176:2007 source 5
- Strength and stability tested to BS EN 16139:2013 level 2
- Seat static weight tested to 227kg

OPTIONS

- Available with pressure relieving foam to reduce the risk of pressure ulcers
- Matching Cadrega Lounge chairs available
- without arms version available (see below)

1CGD1-300
800H | 500W | 555D (mm)
Seat Height: 440mm
Weight: 8.5kg



COLOUR/FINISH

Solid birch legs and frame

FABRIC

Available in a wide choice of fabrics including Vinyl, Waterproof, Non Waterproof and Leather

ASSEMBLY

Arrives assembled and ready to use

DELIVERY

INSTALLATION/FITTING

No fitting required

MAINTENANCE

See upholstered furniture section of our care guidelines

WARRANTY

7 year guarantee (does not include fabrics)

CADREGA DINING CHAIR WITH ARMS

1CGD1-400
800H | 600W | 550D (mm)
Weight: 9kg

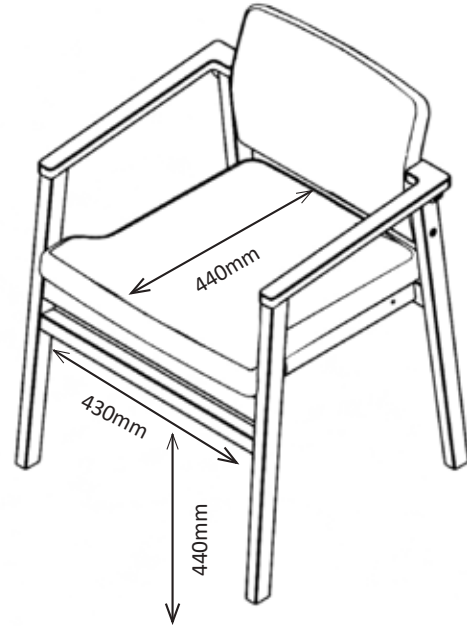
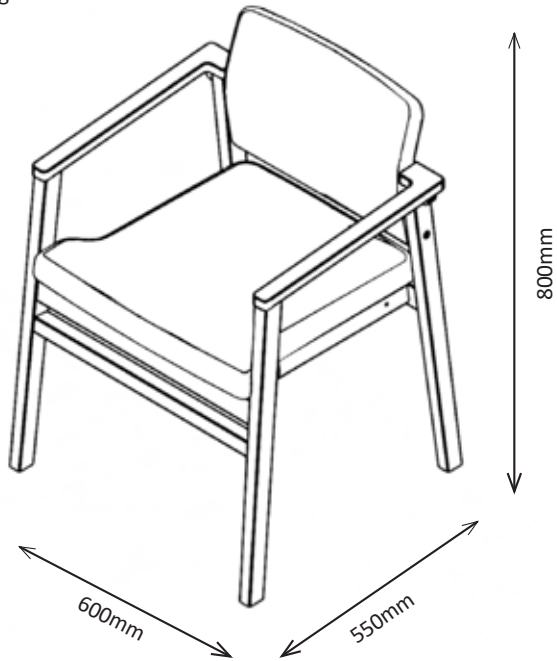

1CGD1-300
800H | 500W | 555D (mm)
Weight: 8.5kg

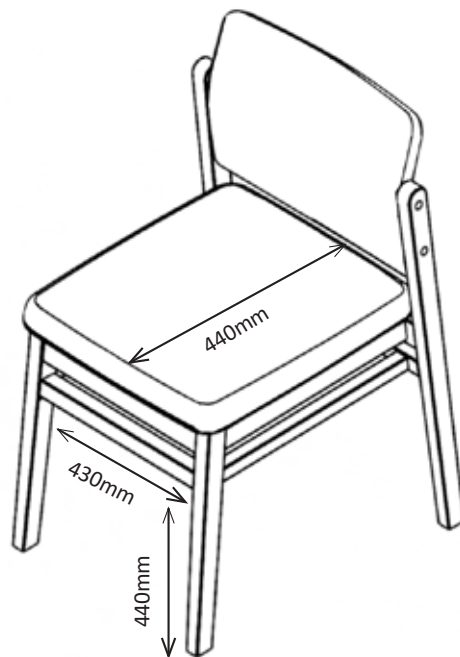
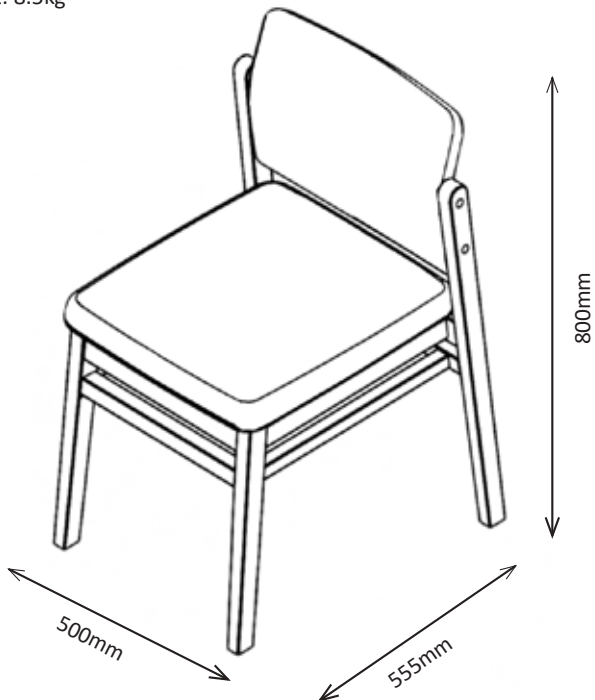

CADREGA LOUNGE HIGH BACK CHAIR

1CGH1-400

1200H | 600W | 660D (mm)

Seat Height: 490mm

Weight: 11.5kg



KEY FEATURES

- Versatile seating range with a minimalist design ethos
- Hygiene-gap between seat and back to prevent dirt and dust gathering
- Seat static weight tested to 227kg
- Solid birch legs and frame

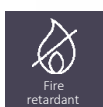

MATERIAL/FABRICATION

Elegantly styled and compact in size, Cadrega is the perfect bedside seating option for patients and visitors, as well as larger spaces like receptions and waiting areas. Cushioned areas made from fire retardant, high density CMHR (combustion modified high resilience) foam is safe for both users and staff.

TEST STANDARDS

- Fire retardant to BS7176:2007 source 5
- Strength and stability tested to BS EN 16139:2013 level 2
- Seat static weight tested to 227kg

OPTIONS

- Available with pressure relieving foam to reduce the risk of pressure ulcers
- Low back version available (see below)

1CGL1-400
850H | 600W | 660D (mm)
Seat Height: 490mm
Weight: 10kg



1CGF-100
300H | 510W | 320D (mm)
Weight: 3kg



COLOUR/FINISH

Solid birch legs and frame

FABRIC

Available in a wide choice of fabrics including Vinyl, Waterproof, Non Waterproof and Leather

ASSEMBLY

Arrives assembled and ready to use

DELIVERY

INSTALLATION/FITTING

No fitting required

MAINTENANCE

See upholstered furniture section of our care guidelines

WARRANTY

7 year guarantee (does not include fabrics)

CADREGA LOUNGE HIGH BACK CHAIR

1CGH1-400
1200H | 600W | 660D (mm)
Weight: 11.5kg

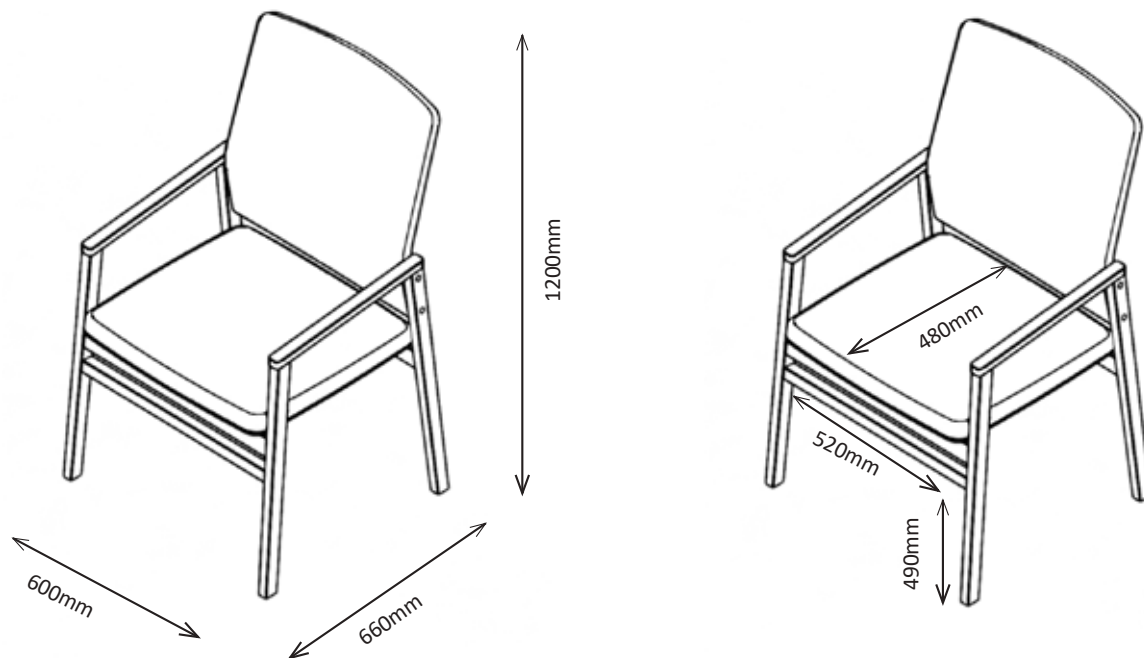

1CGL1-400
850H | 600W | 660D (mm)
Weight: 10kg

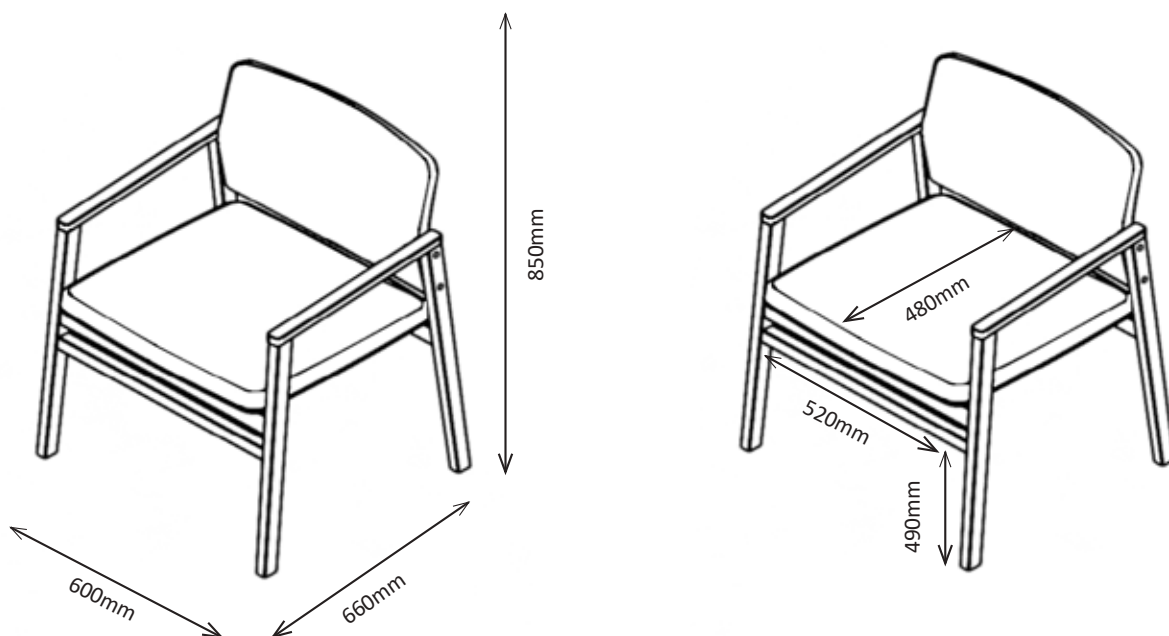

CADREGA LOUNGE LOW BACK CHAIR

1CGL1-400

850H | 600W | 660D (mm)

Seat Height: 490mm

Weight: 10kg



KEY FEATURES

- Versatile seating range with a minimalist design ethos
- Hygiene-gap between seat and back to prevent dirt and dust gathering
- Seat static weight tested to 227kg
- Solid birch legs and frame



MATERIAL/FABRICATION

Elegantly styled and compact in size, Cadrega is the perfect bedside seating option for patients and visitors, as well as larger spaces like receptions and waiting areas. Cushioned areas made from fire retardant, high density CMHR (combustion modified high resilience) foam is safe for both users and staff.

TEST STANDARDS

- Fire retardant to BS7176:2007 source 5
- Strength and stability tested to BS EN 16139:2013 level 2
- Seat static weight tested to 227kg

OPTIONS

- Available with pressure relieving foam to reduce the risk of pressure ulcers
- High back version available (see below)

1CGH1-400
1200H | 600W | 660D (mm)
Seat height 490mm
Weight: 11.5kg



1CGF-100
300H | 510W | 320D (mm)
Weight: 3kg



COLOUR/FINISH

Solid birch legs and frame

FABRIC

Available in a wide choice of fabrics including Vinyl, Waterproof, Non Waterproof and Leather

ASSEMBLY

Arrives assembled and ready to use

DELIVERY

INSTALLATION/FITTING

No fitting required

MAINTENANCE

See upholstered furniture section of our care guidelines

WARRANTY

7 year guarantee (does not include fabrics)

CADREGA LOUNGE LOW BACK CHAIR

1CGL1-400
850H | 600W | 660D (mm)
Weight: 10kg

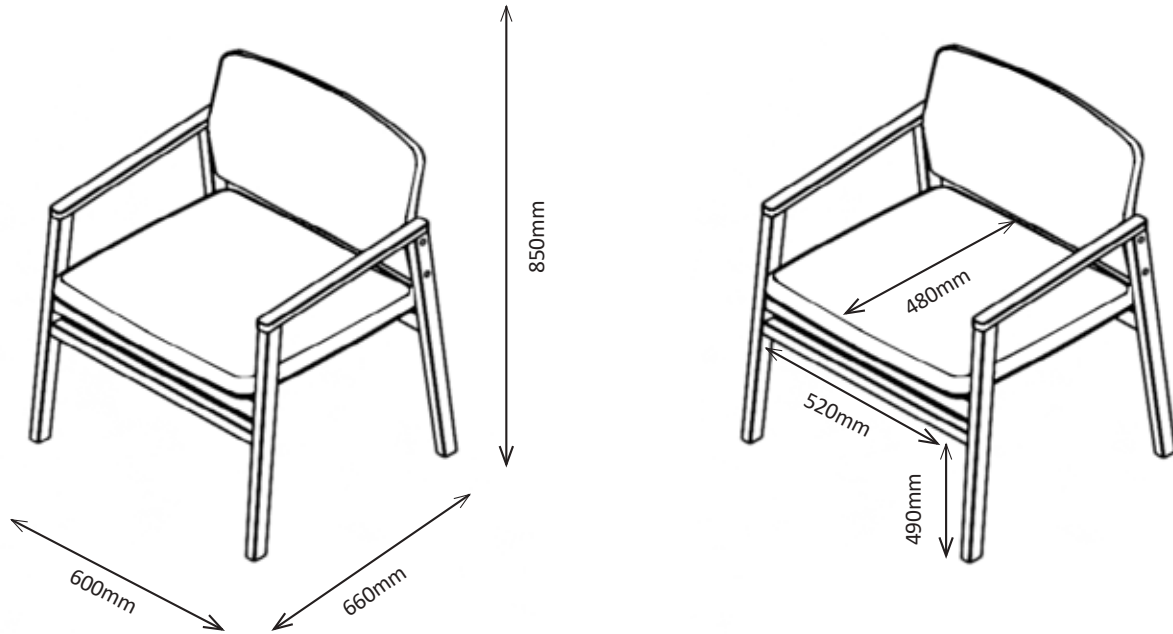

1CGH1-400
1200H | 600W | 660D (mm)
Weight: 11.5kg

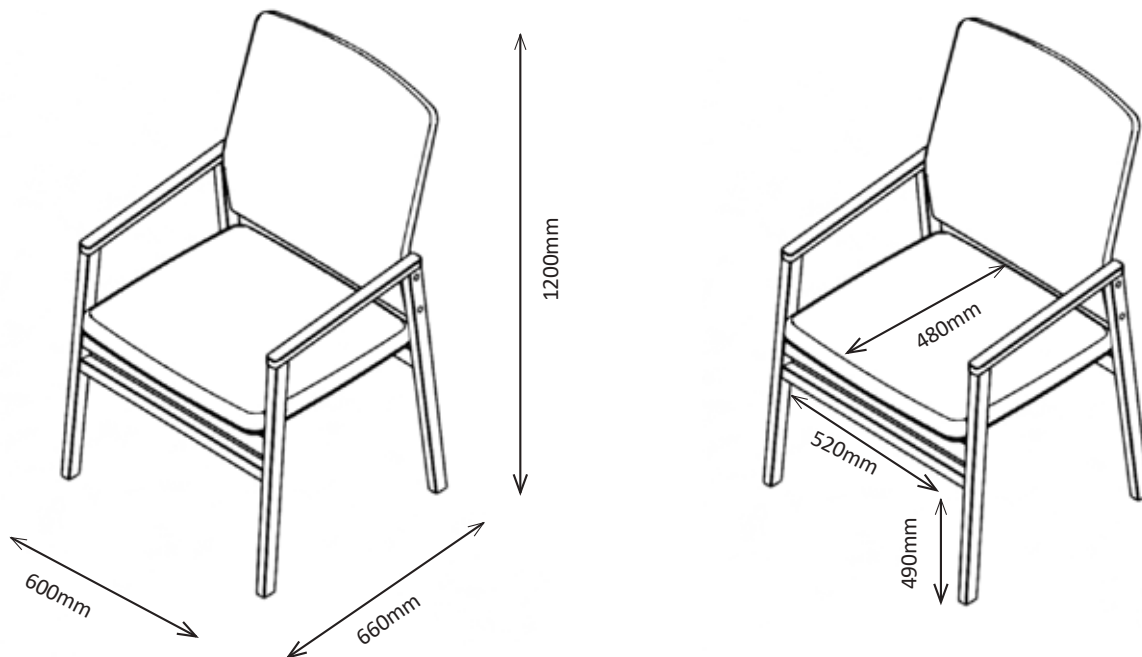

072 836 6193 / 021 201 7199
enquiries@apex-ergo.co.za
www.apex-ergo.co.za



CADREGA LOUNGE BARIATRIC CHAIR

1CGB1-200

1015H | 870W | 660D (mm)

Seat Height: 490mm

Weight: 16kg



KEY FEATURES

- Versatile seating range with a minimalist design ethos
- Hygiene-gap between seat and back to prevent dirt and dust gathering
- Seat static weight tested to 317kg
- Solid birch legs and frame

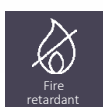

MATERIAL/FABRICATION

Elegantly styled and compact in size, Cadrega is the perfect bedside seating option for patients and visitors, as well as larger spaces like receptions and waiting areas. Cushioned areas made from fire retardant, high density CMHR (combustion modified high resilience) foam is safe for both users and staff.

TEST STANDARDS

- Fire retardant to BS7176:2007 source 5
- Strength and stability tested to BS EN 16139:2013 level 2
- Seat static weight tested to 317kg

OPTIONS

- Available with pressure relieving foam to reduce the risk of pressure ulcers
- Matching Cadrega Lounge and Dining sets available
- Cadrega footstool available (see below)

1CGF-100
300H | 510W | 320D (mm)
Weight: 3kg



COLOUR/FINISH

Solid birch legs and frame

FABRIC

Available in a wide choice of fabrics including Vinyl, Waterproof, Non Waterproof and Leather

ASSEMBLY

Arrives assembled and ready to use

DELIVERY

INSTALLATION/FITTING

No fitting required

MAINTENANCE

See upholstered furniture section of our care guidelines

WARRANTY

7 year guarantee (does not include fabrics)

CADREGA LOUNGE BARIATRIC CHAIR

1CGB1-200
1015H | 870W | 660D (mm)
Weight: 16kg

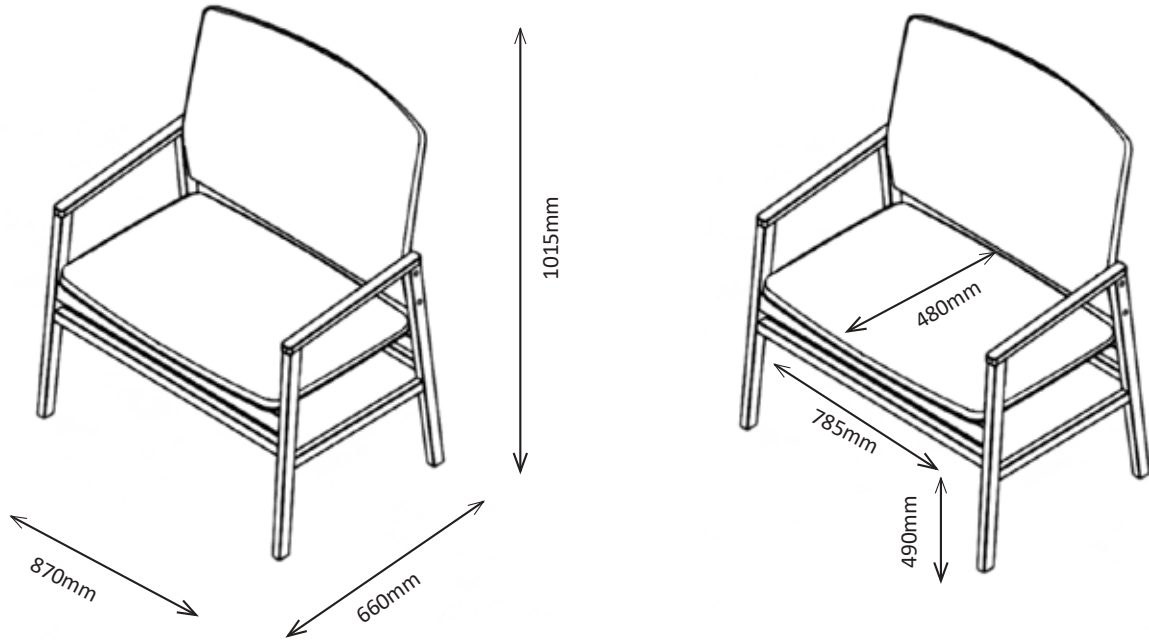

072 836 6193 / 021 201 7199
enquiries@apex-ergo.co.za
www.apex-ergo.co.za



SMILE HIGH BACK CHAIR

1SZH1-118

1175H | 820 W | 720 D (mm)

Seat Height: 400mm

Weight: 40kg



KEY FEATURES

- Subtle wings provide comfort and privacy
- Sweeping seat design acts as an integrated armrest
- Strong and elegant solid metal legs available
- Seat static weight tested to 160kg

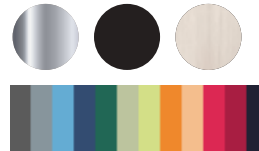

MATERIAL/FABRICATION

The Smile range surrounds, comforts and ensconces its occupants, providing a private and relaxing space. Core to the design (and the name) is a sweeping curved seat platform which rises to become a tactile, integrated armrest. All fabrics are fire retardant, in accordance with testing standards.

TEST STANDARDS

- Strength and stability tested to BS EN 16139:2013
- Fire retardant to BS7176:2007 source 5

OPTIONS

- Black powdercoated leg option available (1SZH1-100)
- See below for wooden leg option available

1SZH1-158
1175H | 820W | 720D (mm)
Seat Height: 400mm



COLOUR/FINISH

Frame available in Stainless Steel, Black powdercoated finish or Birch wooden legs

FABRIC

Available in a wide choice of fabrics including Vinyl, Waterproof, Non Waterproof and Leather

ASSEMBLY

Arrives assembled and ready to use

INSTALLATION/FITTING

No fitting required

MAINTENANCE

See upholstered furniture section of our care guidelines for fabric care instructions

WARRANTY

7 year guarantee (does not include fabrics)